

# Nice HSCU1

Home security control unit

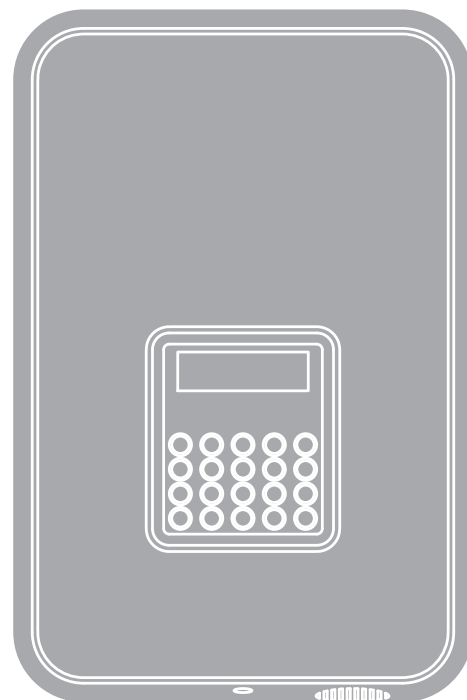

CE 0682

**Instructions and warnings for installation and use**

**Nice**



# Content

|  |    |
|--|----|
| <b>1 – WARNINGS AND GENERAL PRECAUTIONS</b> .....                          | 2  |
| 1.1 - General warnings .....   | 2  |
| 1.2 - Additional warnings for mains-powered appliances .....               | 2  |
| 1.3 - Installation warnings .....  | 2  |
| <b>2 – PRODUCT DESCRIPTION AND INTENDED USE</b> .....                      | 2  |
| 2.1 - Radio communication system between devices .....                     | 2  |
| <b>TECHNICAL GLOSSARY</b> .....  | 3  |
| <b>3 – DESIGNING AN ALARM SYSTEM</b> .....                                 | 4  |
| 3.1 - How to divide up the home and zones to be protected .....            | 4  |
| 3.2 - Where to position the alarm system components .....                  | 4  |
| 3.3 - Elements in the Nice Home Security alarm system .....                | 7  |
| 3.4 - Main features of the Nice Home Security alarm system .....           | 9  |
| <b>4 – INSTALLATION: the control panel and accessories</b> .....           | 10 |
| 4.1 - Set-up of system components for configuration .....                  | 10 |
| 4.2 - Preliminary installation checks and product application limits ..... | 10 |
| 4.3 - Control unit description .....                                       | 10 |
| 4.4 - INSTALLATION: Control unit .....                                     | 11 |
| 4.5 - Door and window opening detector (model HSDID11) .....               | 14 |
| 4.6 - Infrared detector with volumetric lens (model HSDIM11) .....         | 15 |
| 4.7 - Infrared detector with vertical curta in lens (model HSDIM12) .....  | 16 |
| 4.8 - Volumetric detector of glass breakage (model HSDID01) .....          | 17 |
| 4.9 - Fine combustion powder detector (model HSDIS01) .....                | 17 |
| 4.10 - Flooding detector (model HSDIW01) .....                             | 18 |
| 4.11 - 4-channel alarm transmitter (model HSTX4) .....                     | 18 |
| 4.12 - 8-channel radio transmitter (model HSTX8) .....                     | 18 |
| 4.13 - Control keypad (model HSKPS) .....                                  | 19 |
| 4.14 - Outdoor siren via radio (mod. HSSO1) .....                          | 20 |
| 4.15 - Outdoor siren, wired (mod. HSSOC) .....                             | 21 |
| 4.16 - Indoor siren (mod. HSSI) .....                                      | 21 |
| <b>5 – ELECTRICAL CONNECTIONS</b> .....                                    | 22 |
| 5.1 - Warnings .....   | 22 |
| 5.2 - Connections on the control panel .....                               | 22 |
| (models HSCU1GC and HSCU1C only) .....                                     | 22 |
| 5.3 - Connections on siren model HSSOC .....                               | 22 |
| <b>6 – CONTROL PANEL PROGRAMMING</b> .....                                 | 24 |
| 6.1 - Initial start-up and configurations .....                            | 24 |
| 6.2 - Programming menus .....  | 24 |
| <b>7 – PRODUCT MAINTENANCE</b> .....                                       | 29 |
| 7.1 - Replacing the batteries (control panel and accessories) .....        | 29 |
| <b>8 – TROUBLESHOOTING... (troubleshooting guide)</b> .....                | 31 |
| <b>DISPOSAL</b> .....  | 31 |
| <b>9 - OPERATION INSTRUCTIONS</b> .....                                    | 32 |
| 9.1 - Tips when using the system .....                                     | 32 |
| 9.2 - Operations available to the user .....                               | 32 |
| <b>TECHNICAL SPECIFICATIONS</b> .....                                      | 35 |
| <b>EC DECLARATION OF CONFORMITY</b> .....                                  | 36 |

# 1 WARNINGS AND GENERAL PRECAUTIONS

## 1.1 - General warnings

- **This manual contains important instructions and warnings for personal safety during installation: therefore read all instructions before proceeding with installation.** Keep this manual in a safe place for future use. Further information can be found on the web site: "www.niceforyou.com".
- If in doubt during installation, do not attempt further operations and contact a NICE service centre.
- Use of these products for applications other than as specified in these instructions is strictly prohibited.
- Never make any modifications to parts of the product if not envisaged in this manual; operations of this type will lead to malfunctions. NICE declines all liability for damage caused by modified products.
- According to the specific application, check whether additional products are required, such as detection or signalling devices.
- During installation and use of the product, ensure that no foreign bodies (solids or liquids) penetrate any open devices.
- The product packaging material must be disposed of in full observance of current local legislation.
- **Manufacturer liability:** Nice declines all liability for faults caused by incorrect installation, failure to perform maintenance, or improper use. Nice also declines liability for incorrect or incomplete operation of the product or failure to detect intrusion.
- **Guarantee** (summary of terms):  
Nice guarantee company products against concealed defects for a period of 3 years as of the date of manufacture. The guarantee applies to direct purchasers from Nice. No guarantee is envisaged for the end user, who in the event of faults must contact the specific installer or retailer.
- **Exclusions from the guarantee:** the guarantee does not cover aesthetic parts, parts subject to normal wear or normal consumables, such as batteries.

## 1.2 - Additional warnings for mains-powered appliances

- This manual is aimed exclusively at technical personnel qualified for installation.
- Considering the hazards that may occur during system installation and use, maximum safety is only ensured if the product is installed in strict observance of current legislation, standards and regulations.

- Before accessing internal terminals of the product, all power circuits must be disconnected.
- If an automatic circuit breaker trips or a fuse blows, identify and eliminate the fault before restoring normal operating conditions.

## 1.3 - Installation warnings

- Ensure that all material to be used is in perfect condition and suitable for its intended use.
- Ensure that the radio frequencies used by the product are suitable for use in alarm systems adopted in the region of installation.
- The individual parts are designed according to the following environmental classes:
  - Class II environment: general indoor use; temperature range -10 - + 40°C, average humidity 75% (condensate free)
  - Class III environment: protected outdoor use; temperature range -25 - +50°C, average humidity 75% with peaks of 30 days per year between 85 and 95% (condensate free)
- Before proceeding with installation, check the product environmental class as specified in the chapter "Technical specifications".
- Refer to the chapter "Technical Specifications" to check that the radio range of the devices is greater than the physical distance between the various products.
- Ensure that the various devices (sensors, control unit, etc.) are located in areas protected against the risk of impact, and that the fixing surfaces are sufficiently solid.
- Do not place system components near sources of heat to avoid potential damage.
- Each sensor has a specific operating principle: check the relative instruction manual for warnings when selecting the suitable location.

# 2 PRODUCT DESCRIPTION AND INTENDED USE

This control unit and relative accessories are part of the alarm system "Nice Home Security", designed for the protection of residential spaces. **Any use other than as described in this manual is strictly prohibited!**

The alarm system Nice Home Security is not to be considered simply a home burglar alarm, as it is able to detect a variety of events thanks to special sensors: intrusion, break-in attempts (impact-vibration sensor), fire risks (smoke detector) and water leaks (flooding sensor)

The different alarm situations can be indicated locally with audible signals (indoor or outdoor sirens), with voice messages or remotely via telephone calls or text messages.

The system offers maximum installation flexibility: the various elements can interact totally via radio, without the need for any electrical connections or, in some cases, with just short connections (for example the electrical contact of the door may be connected to the volumetric sensor located in the corner of the room) or may be partially wired where the main elements (control unit, siren, telephone dialler) use conventional electrical connections.

Though based on communication via radio waves, the system guarantees total reliability of communication between devices, thanks to the use of 2 separate frequencies (433 and 868 MHz); communication between the main elements is also bidirectional, i.e. when a device sends a command, it waits to receive the confirmation response.

## 2.1 - Radio communication system between devices

The radio system Nice Home Security offers increased flexibility and simpler installation with respect to traditional systems using fixed wiring. In any event, to ensure radio communication without interference (and thus guaranteed), the following factors must be taken into account:

### • Radio transmission inside buildings

Radio signals are electromagnetic waves, which when emitted by a transmitter unit are propagated in the surrounding area through to the receiving unit. On this route, the radio signal may encounter obstacles, which depending on the construction material, may weaken signal power. Common residential buildings may be made up of different materials: **Table 1**, provides information on the range of radio signals inside buildings, considering both the construction materials used and the mounting position.

### • Sources of electromagnetic disturbance

Sources of electromagnetic disturbance are natural sources (terrestrial or solar), occasional sources (e.g. lightning), or intentional artificial sources; the latter are those most frequently present in modern environments. **Table 2**, provides information on possible disturbance and relative risks associated with communication of other systems. As regards the frequencies used by the system, the use of devices with continuous transmission (100%) is prohibited unless below certain power classes. However, illegal devices that operate with continuous transmission are commercially available. The use of a radio system at dual frequency avoids the risk of disturbance unless the specific disturbance covers both frequencies.

TABLE 1

| MATERIAL                                 | ESTIMATED MAXIMUM RANGE                                      |
|--|--|
| In open spaces (outdoors)                | approx. 100 m  |
| Walls in plasterboard/wood               | approx. 50 metres, through a maximum of 5 walls              |
| Walls in brick or concrete               | approx. 30 metres, through a maximum of 3 walls              |
| Walls in reinforced concrete or ceilings | approx. 20 metres, through a maximum of 1 wall or ceiling    |
| Walls in metal                           | not admitted; metal walls constitute virtual total shielding |

**TABLE 2**

| DEVICES  | TYPE OF DISTURBANCE            | PROBABILITY OF DISTURBANCE |
|--|--------------------------------|----------------------------|
| Radio and television transmitters                | continuous                     | high, if close             |
| Variable speed motors                            | continuous                     | low, during use only       |
| UPS units  | continuous during phase of use | medium, during use only    |
| Switching power supply units                     | continuous during phase of use | medium, during use only    |
| Other devices on the same frequency, used < 1%   | occasional                     | very low                   |
| Other devices on the same frequency, used < 100% | continuous (use prohibited)    | very high                  |

**TECHNICAL GLOSSARY**

|  |   |
|--|---|
| <b>Alarm (status)</b>                  | Status of the control unit, which differs according to the envisaged cause of alarm (see audible signals and alarms)  |
| <b>False alarm</b>                     | False alarm, caused by defect and/or fault of one or more appliances  |
| <b>Improper alarm</b>                  | Alarm caused by incorrect installation, technical restraint of appliances or external cause   |
| <b>“Panic” alarm</b>                   | Type of alarm and relative signal implemented to draw attention and prevent possible inadvertent actions  |
| <b>Burglar alarm</b>                   | Type of alarm and relative signals implemented in a situation of danger where it is preferable not to activate sirens, for example calling the police forces or when different aid is required (calling a doctor)                           |
| <b>Technological alarm</b>             | Different and specific type of alarm for detectors of smoke, flooding or other hazardous events   |
| <b>Alarm (zone)</b>                    | Group of detectors, activated/deactivated together, for example the sleeping area may be considered as one zone. Each detector can be programmed to belong to one zone only   |
| <b>24 hour Alarm</b>                   | Type of zone activated at all times; panic, burglar and technological alarms are all of this type   |
| <b>And</b>                             | Control unit function used to reduce the number of improper alarms, enabling the programming of two detectors in the same area and generation of the alarm status only if both transmit an alarm signal (within 30 seconds of one another)  |
| <b>Antidress</b>                       | Keypad function that enables shutoff of an alarm by entering a different code from the normal version, but which activates the robbery alarm at the same time   |
| <b>Detector disable</b>                | Operation to disable a detector through to subsequent reset (due to a fault or other cause)   |
| <b>Domotics</b>                        | System designed to automate appliance commands or devices (open/close doors, turn on lights etc.) according to set rules, for example when specific events occur, such as lights turning off or shutters closed when an alarm is activated. |
| <b>Tampering</b>                       | Attempt to deactivate a device, for example by opening an appliance casing or remove it from a fixture point.   |
| <b>Event log</b>                       | Control unit facility to record to last 200 operations performed and to review events on the display  |
| <b>Pre-alarm (control unit status)</b> | Control unit status prior to actual alarm, for example caused by detectors programmed with an alarm delay   |
| <b>Pre-alarm (siren status)</b>        | Siren status before activation (emission of beeps repeated for approx. 10 seconds)  |
| <b>Alarm delay</b>                     | Interval between transmission of detector and alarm status: programmable for each detector  |
| <b>Detector (or sensor)</b>            | Appliance designed to signal intrusion, transit, opening of doors/windows and any other event that may be a source of a hazard or alarm   |
| <b>Perimeter detector</b>              | Detector applied on doors or windows to protect the building “perimeter”  |
| <b>Volumetric detector</b>             | Indoor detector controlling the entire volume of a room   |
| <b>Test (status of...)</b>             | Control unit status that blocks activation of alarms, for example for test procedures or battery replacement  |
| <b>“Panic” zone</b>                    | Type of zone activated at all times; used when necessary for activation of external sirens and telephone calls via a key on the remote control or keypads   |
| <b>Burglar zone</b>                    | Type of zone activated at all times; used when only telephone call activation is necessary (silent alarm) via a key on the remote control or keypads  |
| <b>Technological zone</b>              | Type of zone activated at all times; used to generate a specific alarm caused by detectors of smoke, flooding or other hazardous events   |

### 3 DESIGNING AN ALARM SYSTEM

To obtain a perfectly operational and efficient system in terms of the intended use, the system must first be designed "at the table", before proceeding to the operating phases described in this manual. In particular it is fundamental to establish the number and type of detectors to be used, and their relative location according to the specific actions required. To ensure a suitable design, a layout of the building should be drawn up where the alarm system is to be installed, specifying the name and position of each device envisaged in the system. This layout drawing will be useful and also decisive in the system configuration phase, for example when the name of each device needs to be memorised.

#### 3.1 - How to divide up the home and zones to be protected

The control panel can be programmed to control the entire home concerned or portions of the latter. For this reason, it is important to first divide up the entire area covered by the system into three "intervention zones" (zones A - B - C), assigning each environment to one of the three zones, according to a suitable and functional logic.

In the case of single buildings, an initial division logic is one of "concentric circles" (see fig. 1). Using this logic, the user can assign, for example, detectors positioned outdoors to zone A, the perimeter detectors (on doors and windows) to zone B and the indoor detectors to zone C. This division enables, for example, dissuasion of intrusion attempts by means of voice messages emitted by the siren (in zone A) before entry, or activation of a siren alarm on the first attempt at

break-in via a door or window (in zone B), or calls to the police only when the indoor detectors (in zone C) signal intrusion.

Another logic used to divide the areas to be protected is one of "uniform blocks" (see fig. 2). Using this logic, the user can assign, for example, the rooms on the ground floor to zone A, the rooms on the first floor to zone B, and the garage to zone C. This division enables, for example, activation of the alarm in the garage (zone C) while normal activities can continue in the rest of the house.

#### 3.2 - Where to position the alarm system components

To decide on the position of the various components of the system, refer to fig. 3 and also ensure the following conditions:

##### • Control unit

- The control panels operate by transmitting and receiving low power radio signals (within the limits as specified in the relevant standards), and therefore must be installed in zones that ensure efficient propagation of the signals. Therefore avoid alcoves, metal cabinets, posts and walls in reinforced concrete; also ensure that there are no large metal surfaces or grids in the vicinity of the control panel, including those embedded in walls.
- The control panel should be positioned at the centre with respect to the other devices (see also paragraph 2.1 "Radio transmission inside buildings").
- The quality of the radio signal received can be checked on the control panel display (see paragraph 9.2.5 "FIELD METER TEST") and if in doubt, test

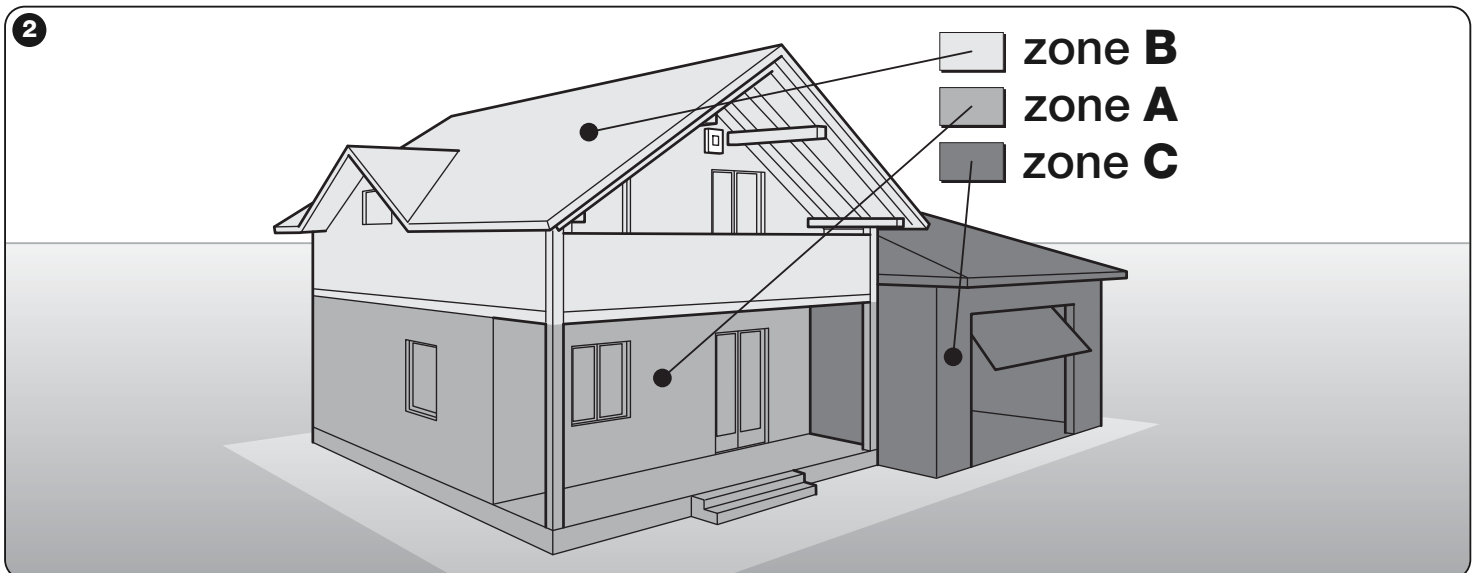
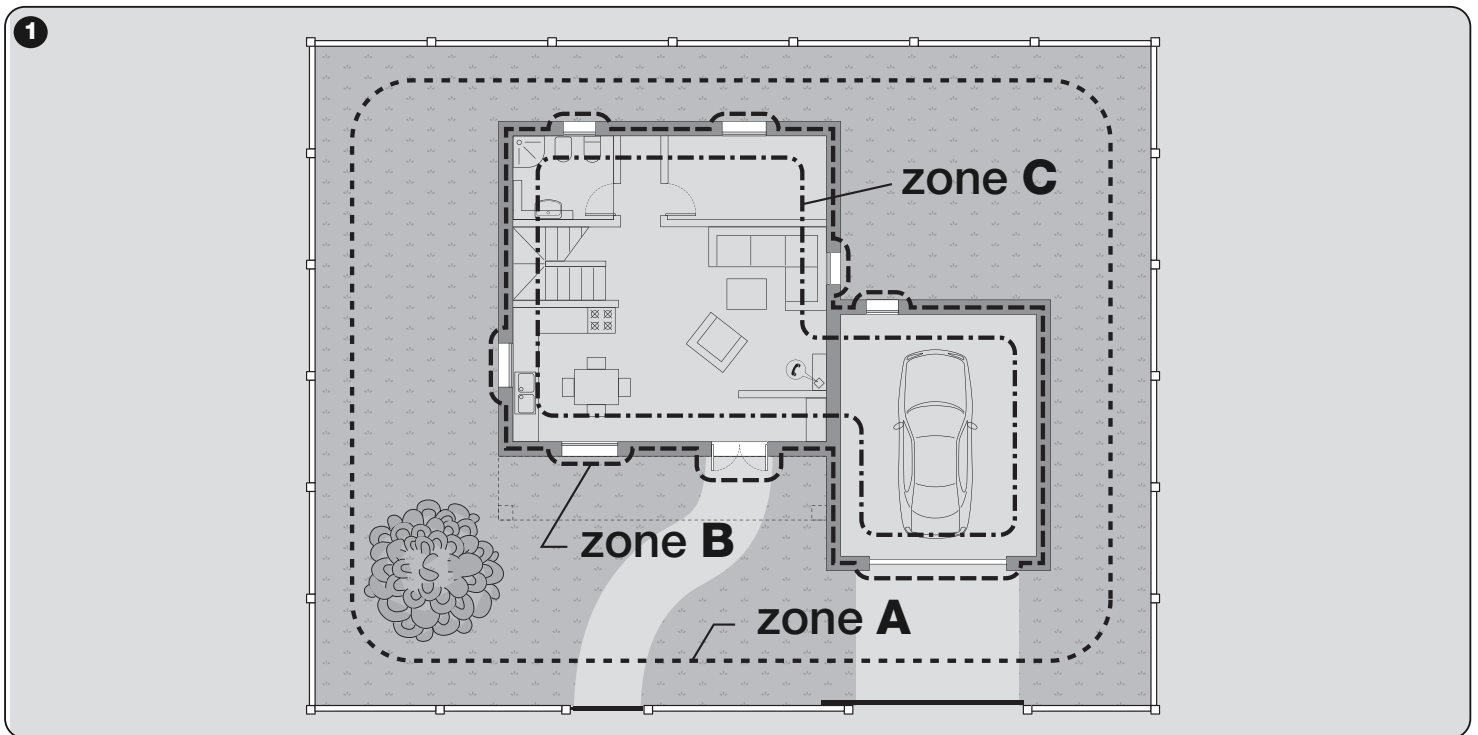



**TABLE 3**

**Door sensor:** this is an intruder sensor designed to protect doors or windows, and signals opening of the latter when the magnet is moved away from the sensor body. The detector is normally mounted on the fixed section of the frame to be protected, on the side opposite the hinge, while the magnet is fitted on the movable section. To increase protection, a second sensor with an NC or pulse type contact can be connected to a terminal (cable detector for rolling shutters). This sensor also has an NO input, which can be used, for example, to connect a flooding sensor.

**Sensor with vertical curtain lens:** this is an intruder detector designed to protect doors or windows; thanks to its curtain lens it signals the movement of persons present only within the close range in front of the sensor (**fig. 4**).

The sensor can be "ceiling-mounted", at the top centre of a door or window (normally between the window and shutter/blind) and in an area protected against adverse weather conditions. The sensor is fitted with a terminal for connection of a second sensor with an NC or pulse type contact (cable detector for rolling shutters). This ensures increased protection, optimising coverage of the area to be protected.

**Volumetric sensor:** this is an intruder detector designed for the protection of rooms; it signals the movement of persons in the protected area. The sensor can be mounted on a wall, in a corner with the special adaptor and can be set at different angles thanks to the articulated support (accessory not supplied).

Sensor operation is based on the detection of movement of heat-emitting bodies; for this reason, and to avoid improper alarm activation, avoid installation in points subject to currents of hot or cold air. If the sensor is active and animals (hot-blooded) use the room, a suitable position and angle should be selected to avoid detection below 50-70 cm from the ground (**fig. 5**); reduce sensor sensitivity if necessary.

The sensor is fitted with a terminal for connection of a second sensor with an NC or pulse type contact (cable detector for rolling shutters). This ensures increased protection, optimising coverage of the area to be protected.

**Volumetric sensors for large environments:** normal volumetric sensors have a sensitive range that is able to cover most standard-size rooms. In the case of large rooms, special sensors are available with surface area coverage of up to 12 m with 120° opening. This type of sensor has a provision to adjust sensitivity to enable precision settings according to the dimensions of the protected area.

**Dual technology sensors:** these are intruder detectors designed for the protection of rooms; they use 2 different technologies (infrared and microwave) to detect the movement of persons in the protected area. Infrared technology detects heat emitted by bodies, while microwave technology (Doppler effect) detects the movement of objects (also cool). The combination of the two technologies achieves maximum efficiency with the minimum risk of improper alarms.

**Sensors for outdoors:** sensors are usually designed for protected indoor environments. These operate correctly within a relatively restricted temperature range and are not completely protected against rain. Special sensors are available for outdoor use, with a temperature range from -25 to +50°C and complete protection against adverse weather conditions. All these sensors have a provision to adjust sensitivity, to enable precision settings according to the dimensions of the protected area and the avoidance of improper alarms caused, for example, by normal moving objects (tree branches), small animals, insects etc.

**Glass breakage sensor:** this sensor detects the breakage of glass (normal glass, double glazing). The detector is fitted with a microphone specially tuned to recognise the specific noise of glass when it breaks; therefore take great care as the sensor may detect other events that produce a similar noise (for example a tumbler falling and breaking on the floor). Activation of this sensor is only recommended if there are no persons in the relative zone who could produce similar sounds.

Also appliances able to generate sudden pressure surges in rooms (air conditioners, fans) may generate improper alarms.

Sound-absorbing materials (such as curtains and carpets) may reduce the sensitivity of the sensor.

The device is optimised with a factory-setting and may not be modified.

To ensure optimal detection, the device must be installed in rooms with an area of 20 to 30 square metres, at a distance of 3 to 6 m from the glass to be protected and at a height of approx. 2 m.

Installation is not recommended in areas with dimensions of less than 10 m<sup>2</sup>, in excessively humid environments (bathrooms or kitchens) and in garages with large metal doors. These conditions can prove critical and may generate improper alarms.

**Fine powder detector:** this is a detector of fine combustion powder (mist or smoke effect) designed for residential applications. A photodiode detects opacity of the air and signals the alarm directly on site (by means of a buzzer) and also via radio to the control unit. It is a sensor able to detect this event on a maximum surface area of 6 x 6 m, and must be positioned on the ceiling at the centre of the area to be protected. Smaller rooms that are not square, such as corridors, require the use of more than one detector.

**Flooding sensor:** this sensor detects flooding caused by water leaks. It is wall-mounted, perfectly flush with the floor surface (the internal sensor is raised by approx. 1 mm from the ground) and positioned in the zone most subject to the risk of water leaks, such as next to a sink or washing machine.

If the floor is not level, the sensor should be placed at the lowest point of the room. The sensor is connected to the NO input of one of the compatible detectors (for example HSDID11).

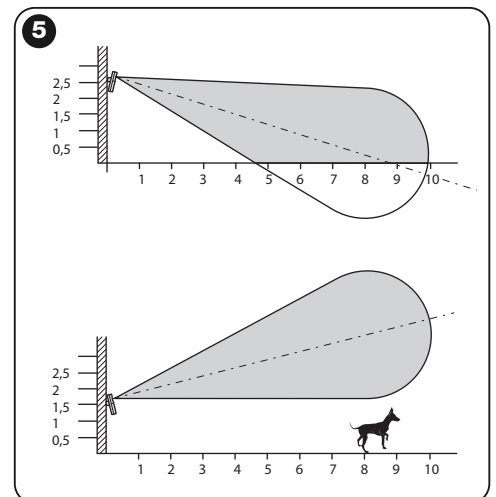
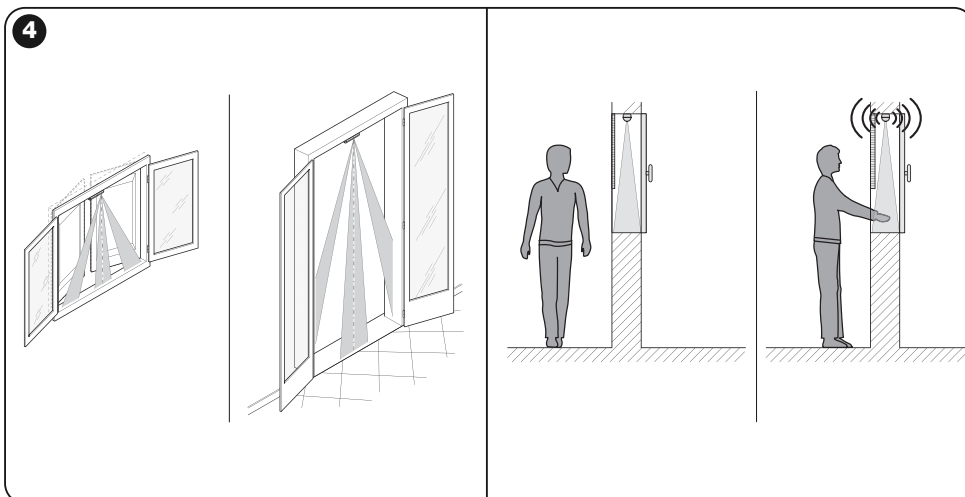



### 3.3 - Elements in the Nice Home Security alarm system

#### Control unit

The control unit is the core of the system; it receives information from the detectors, keypads and transmitters and, according to its status, generates an audible alarm (siren) or sends signals on the fixed or mobile telephone network. It has an incorporated siren for prompt signalling in the event of intrusion. The integrated keypad is used to configure the system and may also be used as an internal control device. The control unit is equipped with telephone diallers to enable connection between the protected location and the outside world, also at great distances. In the event of an alarm, it automatically sends a voice warning message to the pre-set telephone numbers: owner, police forces, etc. The GSM version also enables the unit to send text messages. The operating mode can also be reversed, i.e. commands can be sent to the control unit via the telephone.



HSCU1GC  
HSCU1C  
HSCU1G  
HSCU1

*The models available are:*

|                |   |
|----------------|---|
| <b>HSCU1GC</b> | Control unit for combined alarm systems, wired and via radio, mains powered at 230 Vac. Equipped with PSTN and GSM telephone diallers |
| <b>HSCU1C</b>  | Control unit for combined alarm systems, wired and via radio, mains powered at 230 Vac. Equipped with PSTN telephone dialler          |
| <b>HSCU1G</b>  | Control unit for alarm systems via radio, battery powered Equipped with PSTN and GSM telephone diallers                               |
| <b>HSCU1</b>   | Control unit for alarm systems via radio, battery powered Equipped with PSTN telephone dialler  |

#### Detectors

The detectors serve to control objects and the environment in which they are installed, and to transmit events to the control unit. For efficient control, they must be positioned at strategic points of the room, doors, windows, shutters, porches etc. The types of detectors are classified as follows:

- perimeter, for opening of doors, windows, shutters
- perimeter, via the "vertical curtain" detector
- volumetric, for the detection of presence inside the area covered by the sensor
- dual technology, a combination of infrared and microwave
- outdoor, designed for the protection of external areas, porches, verandas, gardens etc.
- special, for the detection of flooding, fine combustion powders (smoke), glass breakage etc.

Up to 99 detectors via radio can be used or double this number if programmed in pairs, with the "AND" function. Control units with wired connections are fitted with 6 inputs on detectors with wired connections, for association with the zones A - B - C as required.

*The models available are:*

|                |  |
|----------------|--|
| <b>HSDID11</b> | Magnetic contact detector with input for NO contacts and one for NC contacts (also with pulse count); single or differentiated alarm. Intruder sensor  |
| <b>HSDIM11</b> | Infrared detector with volumetric lens with input for second contact (NC or pulse count); single or differentiated alarm. Intruder sensor  |
| <b>HSDIM12</b> | Infrared detector with curtain lens and input for second contact (NC or pulse count); single or differentiated alarm. Intruder sensor  |
| <b>HSDIM21</b> | Infrared detector with volumetric lens for indoor application, in protected areas up to 12 m with 120° opening. With sensitivity adjustment, immediate alarm or alarm on second pulse, protection against opening and removal                                  |
| <b>HSDIM22</b> | Volumetric detector with dual technology, infrared and microwave radar, for indoor application, in protected areas up to 12 m with 90° opening. With sensitivity adjustment, immediate alarm or alarm on second pulse, protection against opening and removal. |
| <b>HSDOM21</b> | Volumetric detector with dual technology, infrared and microwave radar, for outdoor application, in protected areas up to 12 m with 90° opening. With sensitivity adjustment, immediate alarm or alarm on second pulse, protection against opening and removal |
| <b>HSDID01</b> | Volumetric detector of glass breakage  |
| <b>HSDIS01</b> | Fine volatile combustion powder detector   |
| <b>HSDIW01</b> | Flooding detector  |



HSDID11 HSDIM11 HSDIM12 HSDIM21 HSDIM22 HSDOM21 HSDID01 HSDIS01 HSDIW01

#### Transmitters

These represent the most practical and simple means of activating and deactivating the alarm system both inside and outside the rooms; they enable both partial and total activation of the system and the transmission of emergency signals.

*The models available are:*

|              |   |
|--------------|---|
| <b>HSTX4</b> | 4-channel bidirectional radio transmitter for alarm systems   |
| <b>HSTX8</b> | 8-channel bidirectional radio transmitter (4 channels for alarm systems and 4 for automation control) |



HSTX4

HSTX8

## Keypads

The keypad enables control of the entire system or a specifically designated area. It communicates with the control unit and provides specific information such as: "system status", "alarms", "faults", "inputs open" and so on.

*The models available are:*

|              |  |
|--------------|--|
| <b>HSKPS</b> | Bidirectional dual band keypad, for control of alarm system and automation control systems |
| <b>HSSU1</b> | Table-top support for HSKPS keypad   |



## Sirens

The dissuasion devices (sirens), with or without luminous indicators (flashing light) are the main elements of dissuasion in the alarm system. The siren scares and dissuades the intruder, while the flashing light (if fitted) enables illumination of the area where the alarm trips.

*The models available are:*

|              |   |
|--------------|---|
| <b>HSSI</b>  | Indoor siren via radio Sound power 114 dB   |
| <b>HSSOC</b> | Outdoor siren with cable connection to control unit Sound power 116 dB, with built-in flashing light                      |
| <b>HSSO1</b> | Outdoor siren via radio, bidirectional and dual band. Sound power 116 dB, with integrated flashing light and voice board. |



## Actuators

The alarm system Nice Home security, as well as being an alarm for the building, is also able to interact with other devices for domotic management of the environment. By means of special actuators, other devices can be controlled, such as lights, gate opening, shutters etc.

*The models available are:*

|               |  |
|---------------|--|
| <b>HSTT2L</b> | Miniaturised single channel radio receiver for the control of electrical equipment (lights, motors, solenoid valves etc.) compatible with the HS alarm systems                             |
| <b>HSTT2N</b> | Miniaturised 2-channel radio receiver, specifically for the control of electric motors in 2 directions (open-close) for shutters and rolling shutters compatible with the HS alarm systems |



## Repeater

This is a radio signal check and repetition device with HS protocol. It has an input for auxiliary alarm signals and function to indicate a mains power failure.

*The models available are:*

|             |                 |
|-------------|-----------------|
| <b>HSRT</b> | Signal repeater |
|-------------|-----------------|



## Telephone modem

This is a modem to interface between the USB port of a PC and PSTN telephone networks. With the software supplied, this enables remote management of alarm control units connected to the PSTN telephone network.

*The models available are:*

|             |   |
|-------------|---|
| <b>HSMO</b> | Telephone modem for remote connection to control units fitted with PSTN telephone dialler |
|-------------|---|



The combination of all these elements enables complete supervision of all functions in the home.

### 3.4 - Main features of the Nice Home Security alarm system

To exploit the Nice Home Security alarm system to the full, the user needs to know all the features to ensure correct configuration of the entire system according to specific requirements. This section describes the general operation of the control unit and system: operation depends on the devices present and type of settings made during installation.

#### • Types of alarm

There are different types of alarm:

- **Pre-alarm status:** the control unit emits a pre-alarm voice message.
- **Outdoor alarm:** the control unit emits an outdoor pre-alarm voice message via the sirens.
- **General alarm:** activation of all sirens for 3 minutes and dialling of all telephone numbers envisaged for this type of alarm.
- **Panic alarm:** when the system is enabled, this activates all sirens for 3 minutes and dialling of all telephone numbers envisaged for this type of alarm; when the system is partially enabled or disabled, this only activates the sirens via radio.
- **Burglar alarm:** dialling of all telephone numbers envisaged for this type of alarm.
- **Technological alarm:** the control unit emits an intermittent audible signal for 15 seconds and dials all telephone numbers envisaged for this type of alarm.
- **Tampering alarm:** with the system enabled, this generates a "general alarm"; when the system is partially enabled or disabled, this activates an intermittent audible signal for 3 minutes and dials all telephone numbers envisaged for this type of alarm.

#### • Zones

- Three intruder alarm zones are envisaged: zones **A**, **B** and **C**, which respond differently according to whether the "outdoor alarm" function is programmed or not.

##### With Outdoor alarm: Yes

Zone A, suitable for outdoor detectors that generate an "outdoor alarm"

Zone B, suitable for outdoor detectors that generate a "general alarm"

Zone C, suitable for indoor detectors that generate a "general alarm"

##### With Outdoor alarm: No

Zone A, suitable for perimeter detectors, for example on the ground floor, that generate a "general alarm"

Zone B, suitable for perimeter detectors, for example on the first floor, that generate a "general alarm"

Zone C, suitable for indoor detectors that generate a "general alarm"

- As well as alarm zones A, B and C, which can be activated or deactivated as required; other constantly active zones are also available (24 hour zones)

##### Accessory alarm zones, always active

"Panic" zone, activated in the event of necessity via the remote control or keypads

"Burglar" zone, activated in the event of necessity via the remote control or keypads

"Technological" zone, activated by the relative detectors of hazardous events, smoke, flooding etc..

#### • Alarm activation/deactivation

The following can be used to activate/deactivate the alarm:

- up to 32 bidirectional transmitters, with 4 keys, for deactivation or total activation of the 3 zones (A+B+C) or partial activation (A+B or B+C), with visual confirmation of the operation performed;
- up to 32 five-digit codes for deactivation, which depends on the zones enabled on the transmitter during the programming phase, and total or partial activation, usable on the control panel or keypads;
- activation override: the user can override to automatic alarm activation at a set time;
- via telephone calls on PSTN network or GSM (for mod. HSCU1GC only);
- on models with wired connections (mod. HSCU1GC and mod. HSCU1C) a switch can be connected to alarm activation/deactivation.

#### • Siren operation

- **Indoor sirens:** activated for 3 minutes in the event of "general", "tampering" or "panic" alarms. Emission of an audible signal; 3 beeps on total or partial activation and 1 beep on deactivation. The volume can be adjusted through to level zero.

- **Outdoor sirens:** activated for 3 minutes in the event of "general", "tampering" or "panic" alarms. To avoid disturbance, if the system has been left activated, the siren is activated after a pre-alarm interval of approx. 10 seconds, during which a series of beeps are emitted.

Emission of an audible signal on activation and deactivation (3 beeps on total or partial activation and 1 beep on deactivation).

The volume can be adjusted through to level zero. The flashing light flashes during siren activation.

In the case of an "outdoor" alarm, the siren remains silent, but a series of beeps are emitted for 3 minutes.

On HSSO1 sirens, equipped with voice board, two different messages can be recorded, which can be emitted in the event of a "pre-alarm" or "general alarm" caused by a detector belonging to a zone where the "external alarm" function has been enabled.

#### • Telephone calls

- **On fixed PSTN line:** up to 6 voice messages can be recorded for each specific event (see section 6.2.2), which are transmitted to up to 63 users, the numbers of whom are programmed accordingly.

- **On GSM network:** the same 6 messages envisaged for the fixed line can be transmitted via GSM. As well as the voice message, a corresponding text message can also be sent. A further 11 factory-set "technical" text messages (see section 6.2.3) are transmitted on the occurrence of specific events.

- **Calls to alarm receiving centres:** the control units can communicate with the digital protocol Contact ID and CESA 200 Baud, for contact with alarm receiving centres. For specific settings, request the relative instructions from the Nice service centre.

- **Remote assistance calls:** the control units can be set up to enable the professional installer to make a remote connection for checks and set-up operations on the system (see section 6.2.7 - 9.2.8).

#### • Domotic functions

- **Programmable clock:** the control unit is fitted with a programmable clock for automatic activation.

- **Relay outputs** (for models HSCU1GC and HSCU1C only): two relays are available for the control of electrical appliances, which can be activated via the clock by a telephone call or via specific control unit functions (see chapter 9.2.7 - 9.2.9).

- **Outputs via radio:** 16 commands via radio are available for actuator models HSTT2L and HSTT2N, which can be activated via a telephone call or directly via transmitters, keypads or detectors (see chapter 9.2.9).

## 4 INSTALLATION: the control panel and accessories

### 4.1 - Set-up of system components for configuration

All system devices communicate via radio therefore the system should be configured on a table **before** final installation of all devices.

The following operations should be carried out for **control units that require electrical connections**:

- 1) configuration of radio devices on a table;
- 2) final installation of each device;
- 3) electrical connections.

To avoid errors, operation and reception problems proceed as follows:

**The perfect radio coverage of the devices can be checked using this procedure before installation.**

- a) Open the packaging and lay out all the products on a table;
- b) Insert the "voice guide" memory board supplied in the control panel; on the GSM version also insert the "SIM" card (see installation paragraph);
- c) Power up the control unit and program it in "device acquisition" mode;
- d) Put the batteries in the devices which will then be acquired one by one by the control unit;
- e) Test operation of the devices;
- f) Place the control unit in the envisaged point (without fixing);
- g) Place all the other devices in the envisaged points (without fixing);
- h) Check that each device has sufficient coverage for radio communication (see paragraph "Testing the control unit").

On the GSM versions check that the signal strength and coverage are sufficient;

- h) Install all devices;
- i) If necessary, configure the control unit with the advanced and detailed functions.

The next paragraphs describe the control panel installation phases (for all models) and electrical connections of versions that envisage wiring.

### 4.2 - Preliminary installation checks and product application limits

Before proceeding with installation, check the condition of the product, suitability of the selected model and suitability of the intended installation environment.

- Check that all use conditions are within the "product application limits" and as stated in the "Product technical specifications".
- Check that the intended installation area is suitable for the overall size of the product.
- Check that the fixing surfaces are sufficiently solid and that the areas are protected against the risk of impact.
- Install the control panel at at least 1 metre from the ground.
- The product can only be used with products part of the Nice Home Security system.

### 4.3 - Control unit description

All control unit models have a **system memory board with voice guide** ("I" fig. 6A - 6B). The voice of this guide is in the language of this manual; versions in a different language are available on request.

This memory board is supplied with this manual and must be inserted in the control unit before starting installation and with the power off (see paragraph 4.4.2). This board records all system parameters (excluding voice messages recorded by the installer or user) of every programming operation and can be transferred from one control unit to another.

Some control unit models (models HSCU1GC and HSCU1G) are equipped with a GSM telephone dialler.

The SIM card must be inserted before starting installation and with the power off (see paragraph 4.4.2). The SIM card can be of any operator and subject to any type of contract (only the "voice" and text messaging services are used) but it must be configured with the PIN code = "1234" or have the function "access without PIN" active: this operation can be carried out by inserting the SIM card into any GSM telephone.

#### Control unit description:

**Fig. 6A** mod. HSCU1G and HSCU1 - **Fig. 6B** mod. HSCU1GC and HSCU1C

- a - Display
- b - Keypad
- c - Microphone
- d - Socket for PSTN telephone line
- e - Hole for cable routing
- f - PC connection socket
- g - Terminal board for electrical connections (models HSCU1G and HSCU1GC)
- h - Internal siren
- i - Loudspeaker
- l - System memory board with voice guide

- m - GSM SIM (models HSCU1G and HSCU1GC)
- n - Battery pack (models HSCU1G and HSCU1)
- o - Buffer battery (models HSCU1GC and HSCU1C)
- p - Electric mains power terminal (models HSCU1GC and HSCU1C)
- q - Power supply unit (models HSCU1GC and HSCU1C)
- r - GSM antenna

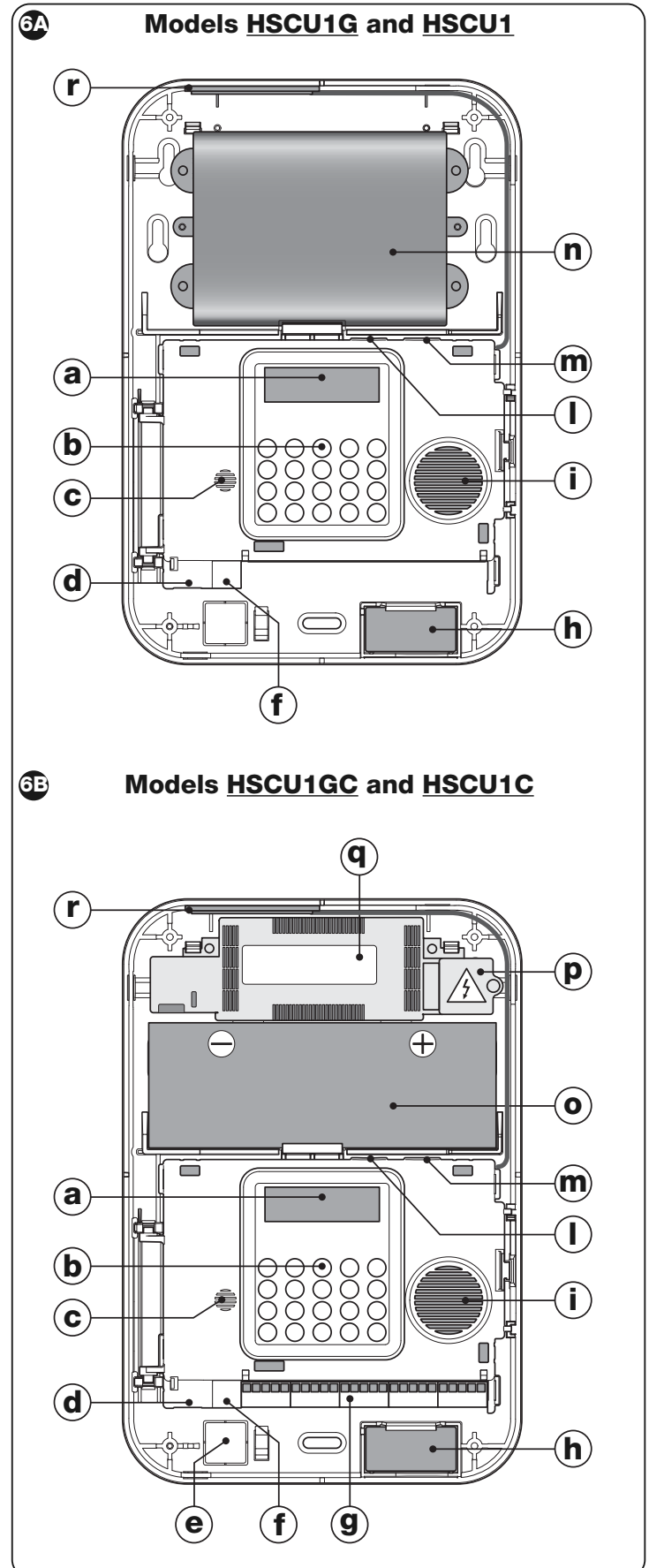

## 4.4 - INSTALLATION: Control unit (models HSCU1GC - HSCU1C and HSCU1G - HSCU1)

### 4.4.1 - Warnings

Before proceeding with installation carefully read paragraphs 4.1 - 4.2 - 4.3.

### 4.4.2 - INSTALLATION

01. Remove the protection grille (fig. 7-A) and the cover (fig. 7-B) to open the housing;
02. Unhook the side hook so that the body of the control unit can be rotated (fig. 8);
03. Insert the memory board supplied; ensure that it is correctly inserted in the internal connector guides (fig. 9).  
On control unit models HSCU1GC and HSCU1G (with GSM) also insert the SIM card (fig. 10).
04. Before fixing the housing, the "anti-lever" system can be activated if required on the rear tampering detector (fig. 11):
  - a) remove part "a" as shown and **set aside**
  - b) remove part "b" as shown and throw it away;
05. For models HSCU1GC and HSCU1C: make a hole for the cables (fig. 12) and route the electric power cables through the hole (fig. 13);
06. Refit the control body unit in its seat (fig. 14);
07. Mark the 3 fixing points shown in fig. 15 on the wall. If the "anti-lever" system has been activated also mark the 4th point for part "a" (fig. 15);
08. Drill holes in the wall at the 3 fixing points and insert the screws and plugs supplied (fig. 16). If the "anti-lever" system has been activated also drill a hole at the 4th point and insert the plug and part "a", previously set aside (fig. 16);

09. Fix the control unit to the wall using the screws supplied (fig. 17);

10. Electrical connections:

- For models HSCU1GC and HSCU1C:

make the electrical connections and insert the buffer battery as described in chapter 5.

- For models HSCU1G and HSCU1:

connect the battery pack as shown in fig. 18;

11. Close the housing (fig. 19).

12. Now proceed with the installation of the various devices as envisaged (see paragraph 4.5) and program the control unit (see chapter 6).

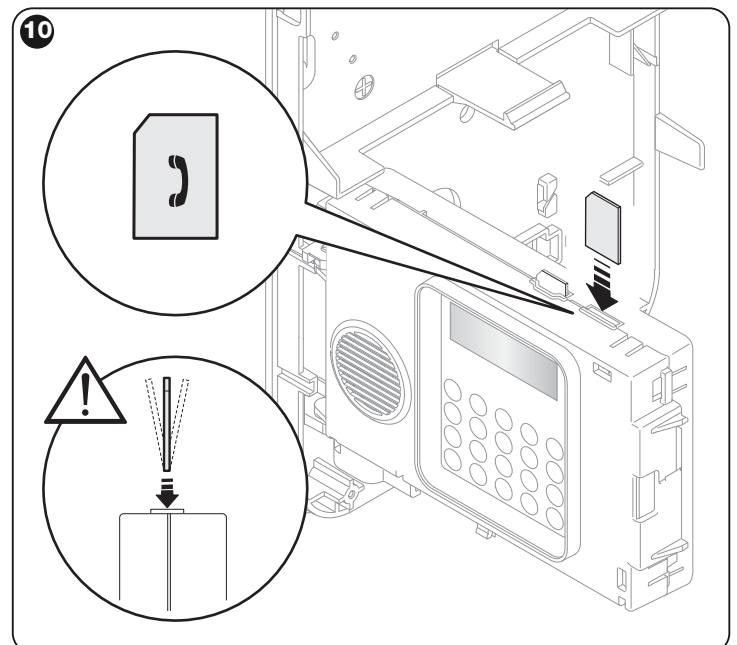
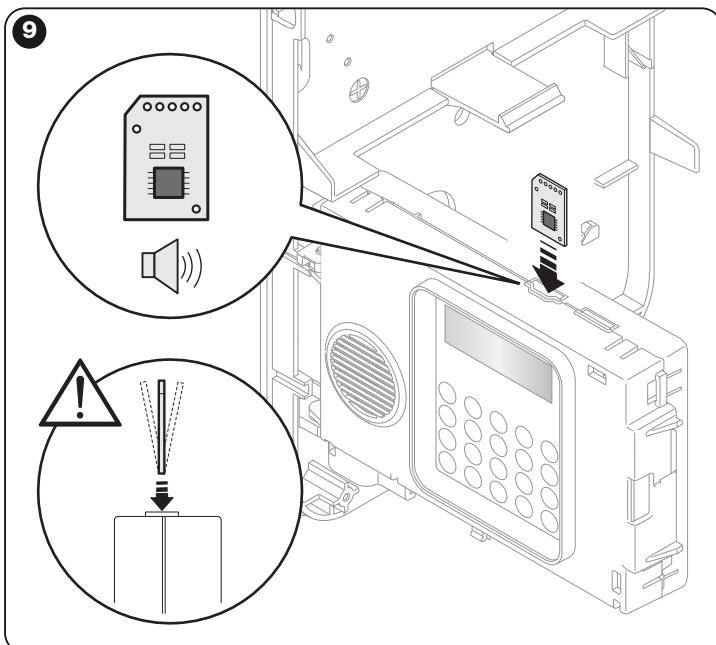
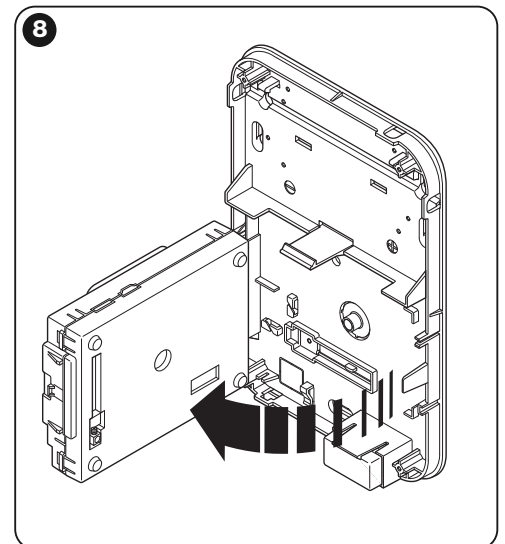
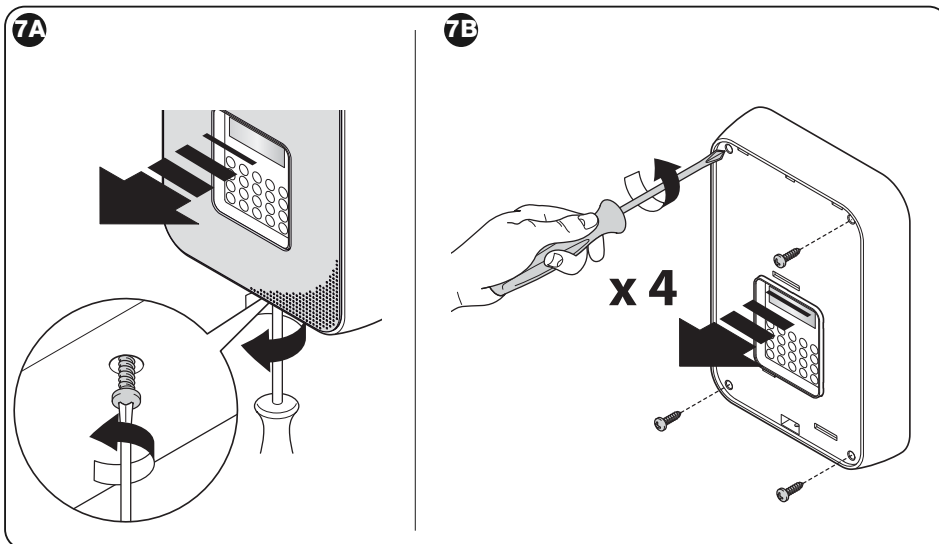

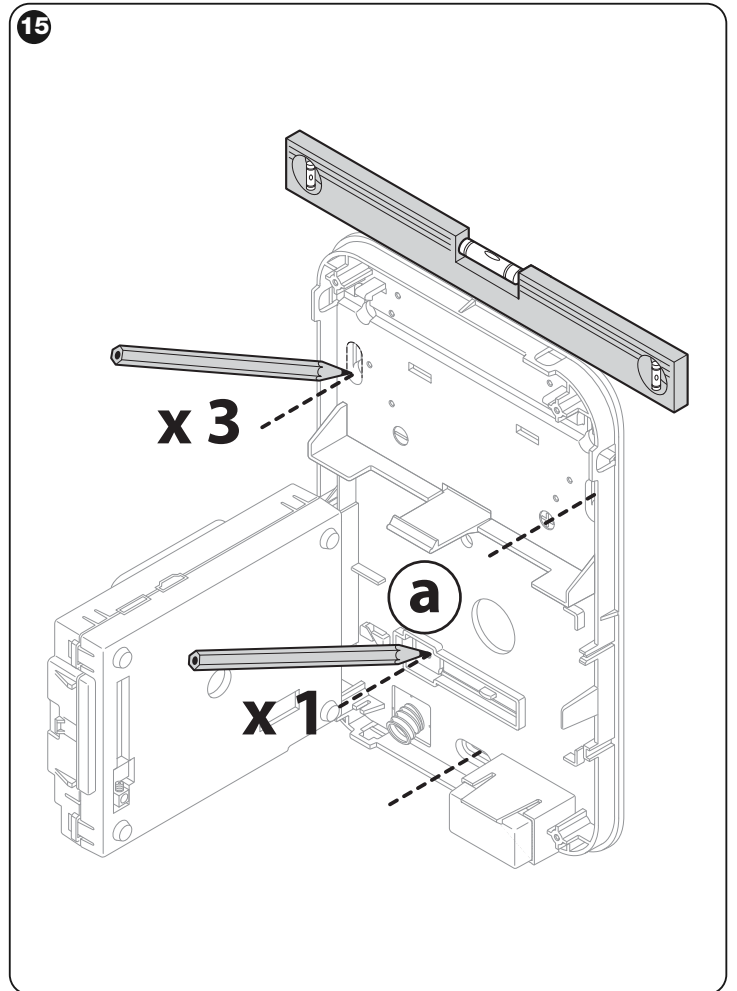
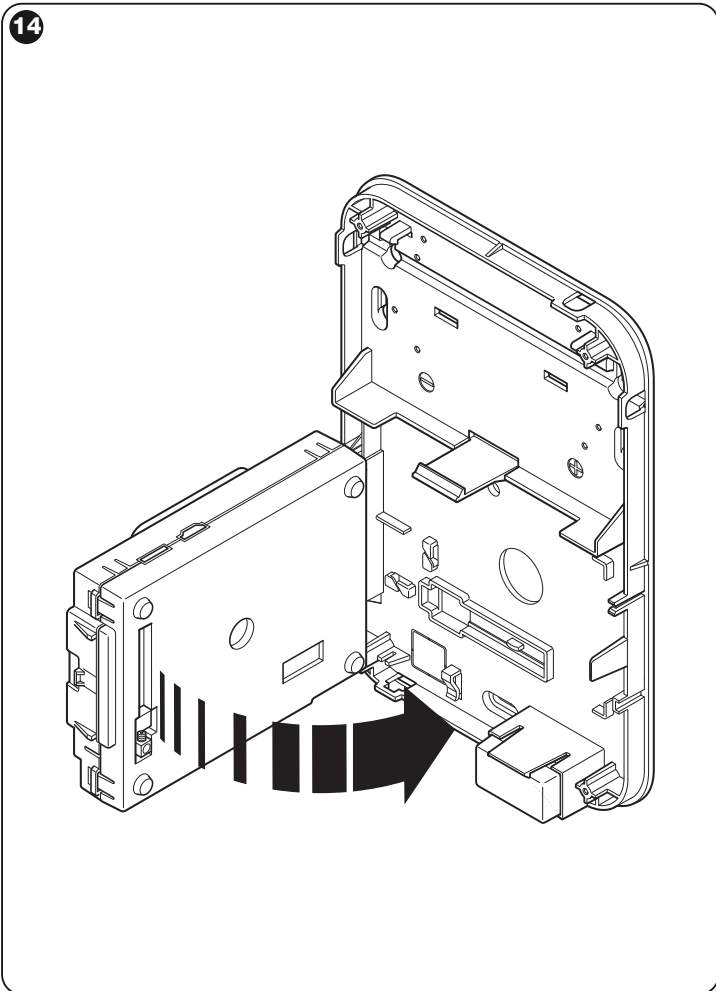
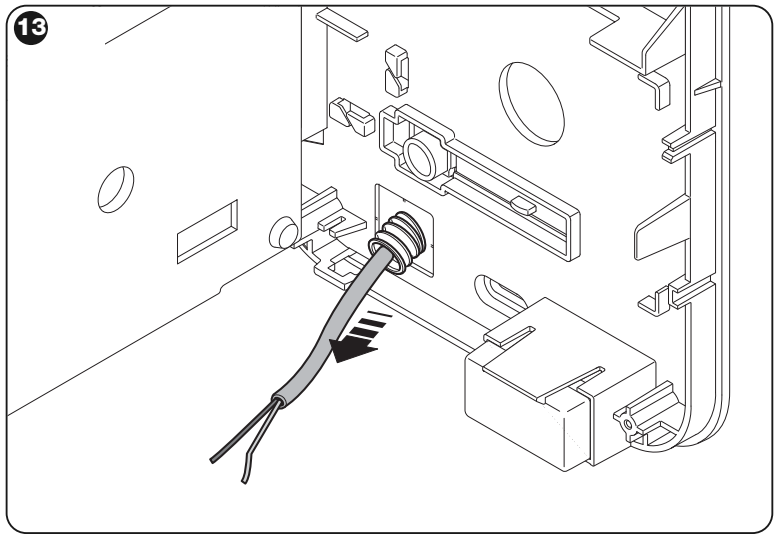
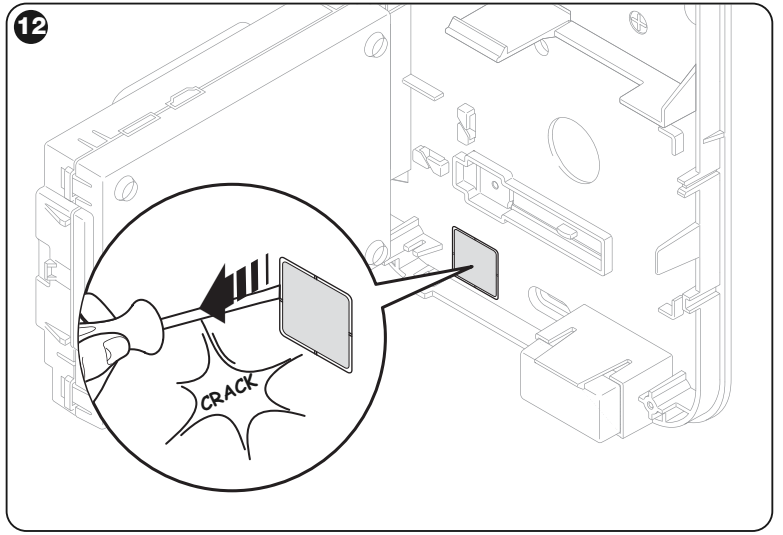
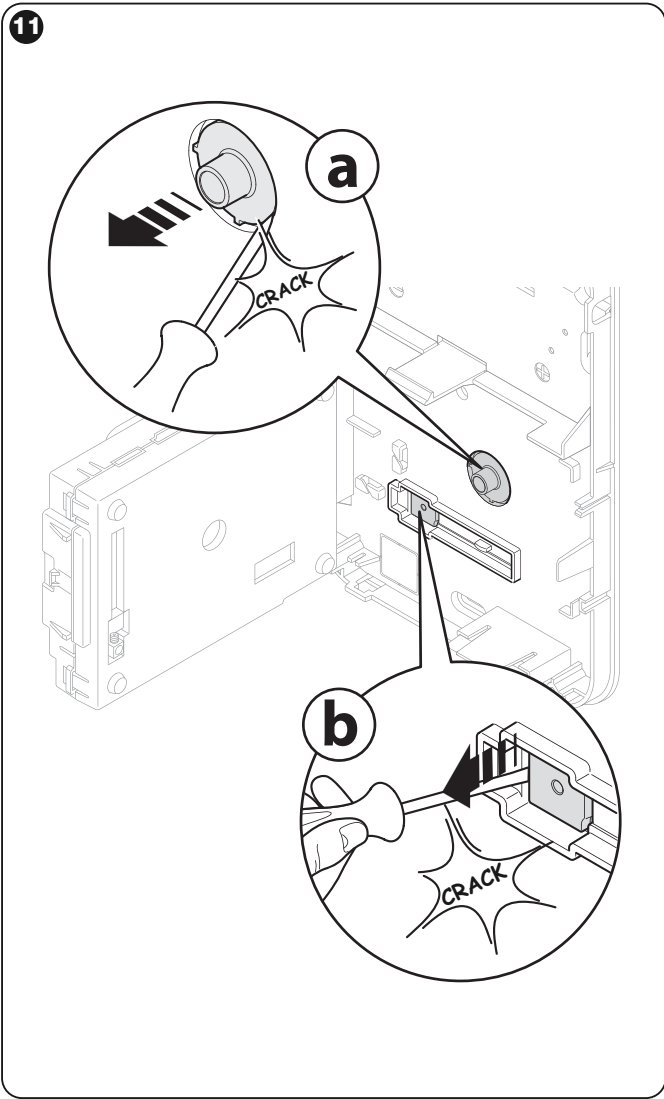

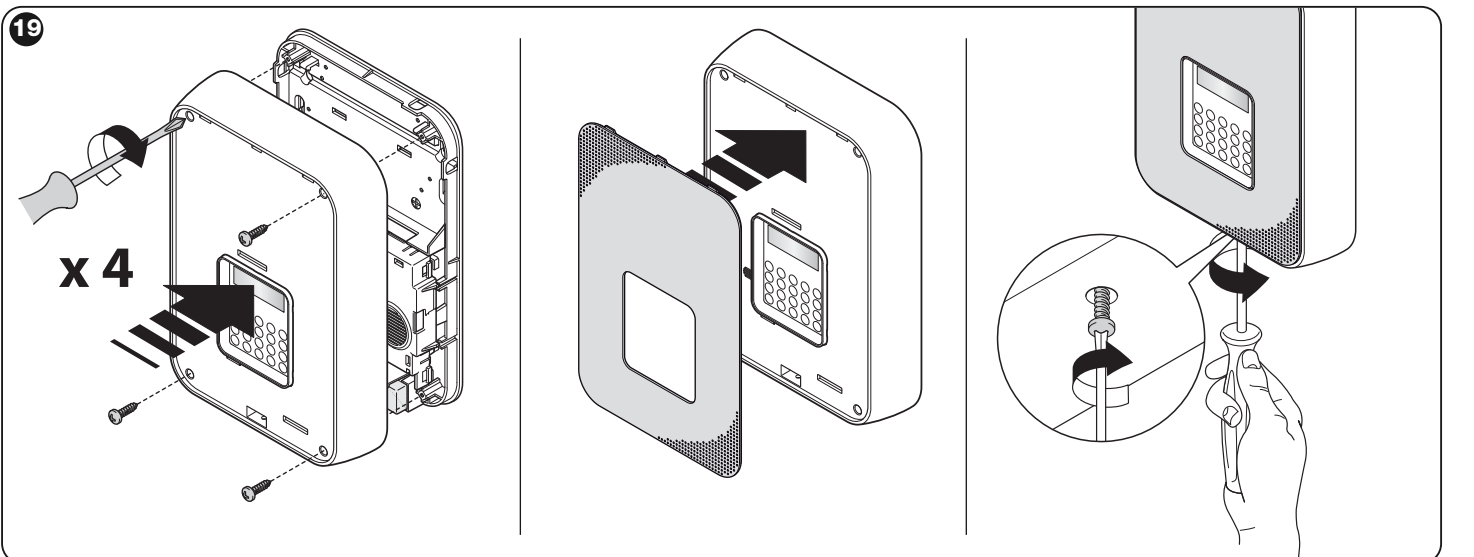
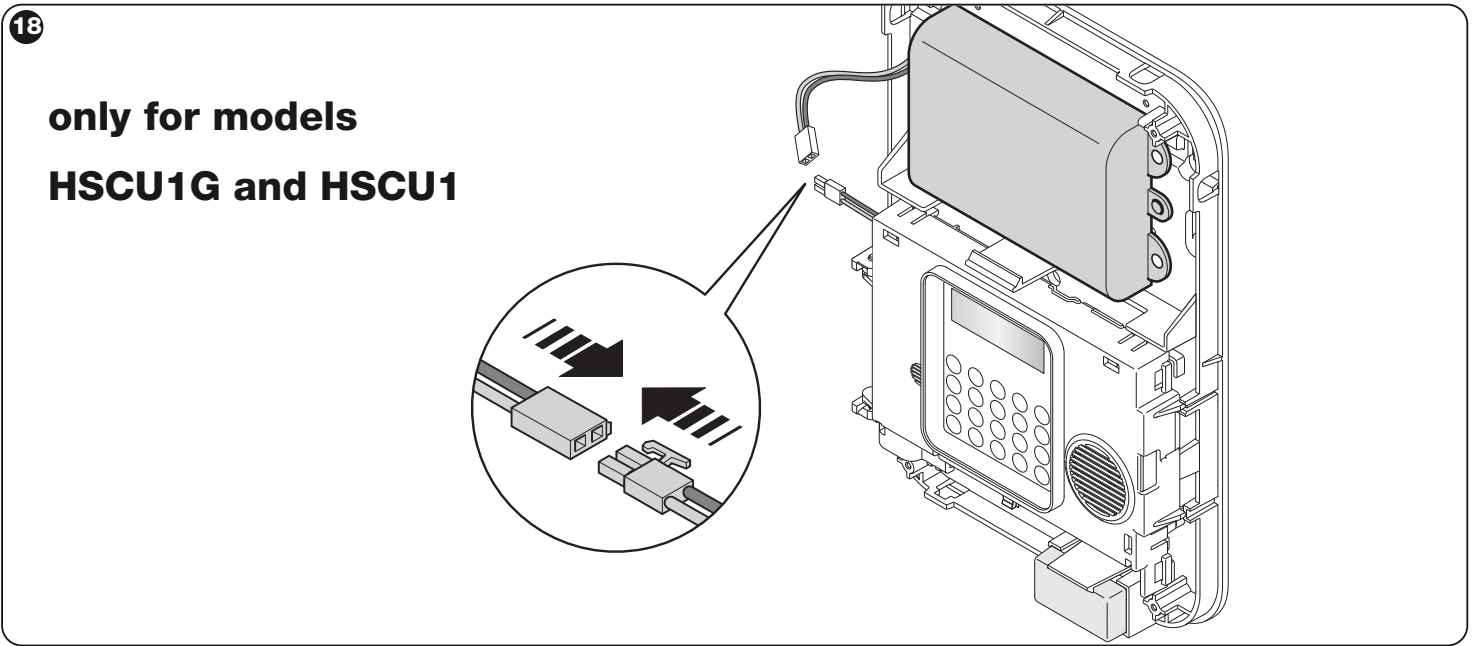
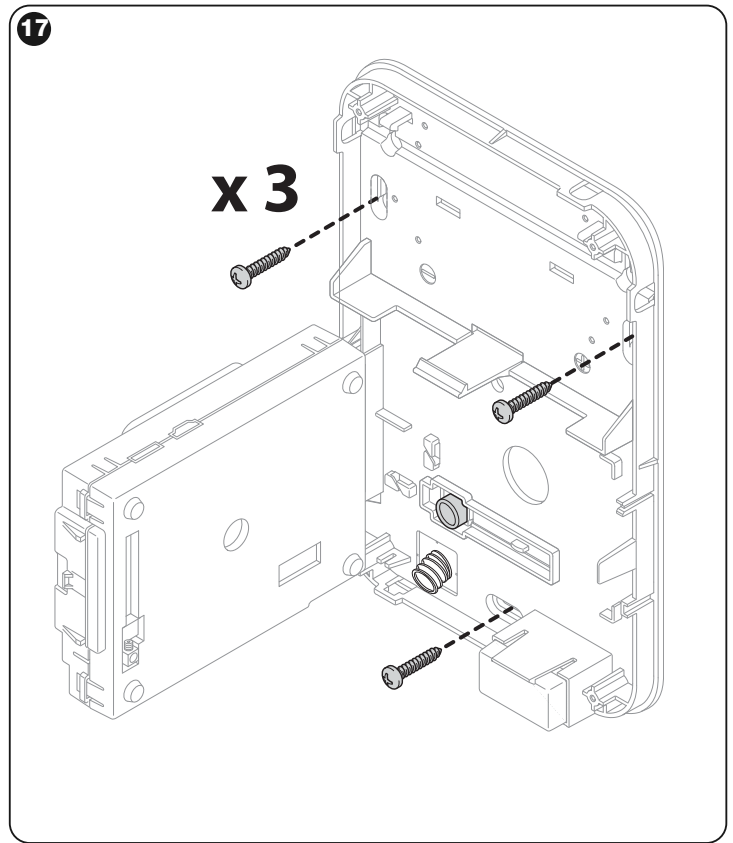
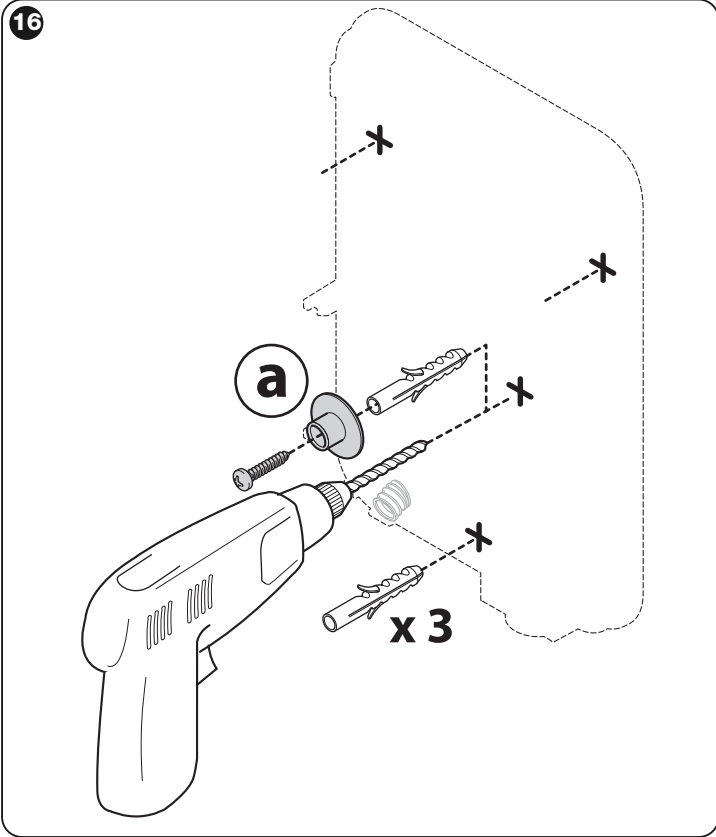

## 4.5 - Door and window opening detector (model HSDID11)

### 4.5.1 - SPECIAL WARNINGS

To avoid intentional damage, install the product in a position that is difficult to reach.

### 4.5.2 - PRODUCT DESCRIPTION AND INTENDED USE

HSDID11 is a detector for doors and windows that signals opening as the magnet is separated from the sensor body. Suitable for use in protected indoor and outdoor areas. It detects opening of a door or window and signals it via radio to the associated control unit. Any other use is to be considered improper and prohibited! Nice declines all liability for damage resulting from improper use of the product and any use other than as specified in this manual.

### 4.5.3 - OPERATION

HSDID11 is a detector suitable to protect doors and windows in case of opening (separation of the magnet from the sensor).

To increase protection it is fitted with a second input for NC type contacts which can be used to connect another sensor, also pulse type (detector for rolling shutters).

As well as the NC input there is an input for NO contacts which can be used to connect NO type sensors such as the flooding detector HSDIW01.

The alarm can be single or differentiated for the different detections of the magnetic sensor and NC + NO input.

Communication is completely via radio with dual band technology; battery operated – standard 9 V.

Equipped with LED indicator visible from the outside.

#### Types of alarm signals:

- **Intruder alarm:** alarm signal following opening of door or window.
- **Second alarm:** the HSDID11 can be programmed to transmit 2 different alarms (transmission of 2 different codes): one for the magnetic contact and one for the input of the NC or NO contacts.
- **Supervision:** transmission of a signal every 40 minutes to indicate that the system is running.
- **Anti-opening protection:** the opening of the battery compartment and/or separation of the device from the surface on which it is fixed triggers the “tampering” alarm. To avoid this set the control unit to “TEST” mode before opening the sensor.
- **External LED:**
  - when the LED illuminates for 1 second it indicates that there has been an alarm signal;
  - after the alarm signal, if the LED flashes quickly 4 times (timed with 4 acoustic beeps) it means that the battery is almost discharged.

Replace the battery only when the control unit indicates that the detector has a discharged battery. To replace the battery see the instruction manual of the HSDID11.

### 4.5.4 - INSTALLATION

For installation operations see the instruction manual of the HSDID11.

### 4.5.5 - PROGRAMMING OF DIP SWITCHES

**Caution!** – To program the “dip-switches” remove the battery from the device; remove the battery also to make any changes and then reprogram.

See fig. 20:

- 1 OFF** = alarm signal only when open.
- 1 ON** = alarm signal when open and closed (alarm end).

- 2 OFF** = **non-differentiated alarm** signal: single code for both alarms.
- 2 ON** = **differentiated alarm** signal: 2 different codes, one for the detector alarm and one for the alarm of the NC or NO input.

- 3 OFF** = **immediate** alarm signal on opening of NC input or closure of NO input.
- 3 ON** = alarm signal **after 6 pulses** on NC input.

- 4 OFF** = intruder sensor disabled (for areas subject to vibrations).
- 4 ON** = intruder sensor enabled (alarm signal in common with opening signal).

- 5\* OFF** = Anti-removal/tamper protection **enabled**.
- 5\* ON** = Anti-removal/tamper protection **disabled** (to be used when fixed on irregular or unstable surfaces)

**6\*** = Not used.

(\* available from April 2010.

### 4.5.6 - CONNECTION OF EXTERNAL DEVICES

To connect external devices using wires to the NC or NO contact see fig. 21.

With **dip-switch 3** set to “ON” the input is suitable for controlling rolling shutter detectors or inertia sensors where the alarm is signalled after 6 pulses in 30 seconds. The NC input is automatically activated by closing the contact for at least 10 seconds after inserting the battery.

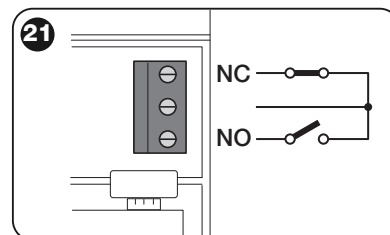

To memorise the detector in the control unit see chapter 6.

If the NC input on the terminal board is used and a differentiated alarm is required, the following memorisation steps must be carried out:

- at first leave the dip switch N° 2 = OFF (non-differentiated alarm)
- set the control unit for memorisation of the first code (magnetic detector); then insert the battery to carry out memorisation
- set the control unit for memorisation of the second code (NC input); then move dip switch N° 2 = ON when requested to “insert battery in detector”.

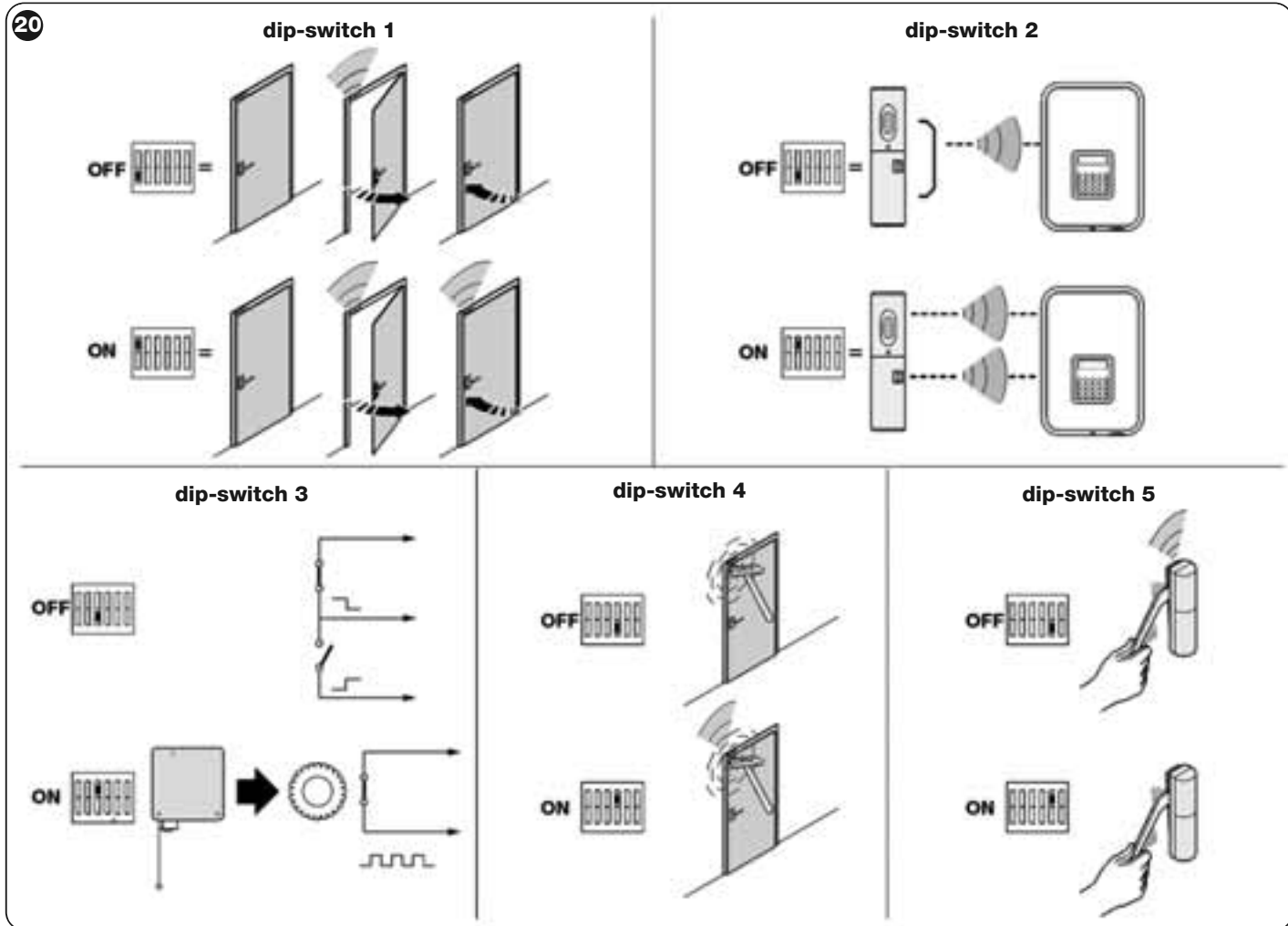



## 4.6 - Infrared detector with volumetric lens (model HSDIM11)

### 4.6.1 - SPECIAL WARNINGS

To avoid intentional damage, install the product in a position that is difficult to reach

- Do not install the product near possible hot or cold air turbulences or where there are animals (hot blooded).
- If pets enter the environment controlled by the sensor the sensor must be adequately positioned and aimed so that the sensitivity area is 50-70 cm above the ground as shown in **fig. 23**; if necessary, reduce sensitivity of the sensor.

### 4.6.2 - PRODUCT DESCRIPTION AND INTENDED USE

HSDIM11 is an infrared detector with volumetric lens for indoor use; it detects the movement of an intruder in the protected area and transmits it via radio to the control unit to which it is associated. Any other use is to be considered improper and prohibited! Nice declines all liability for damage resulting from improper use of the product and any use other than that specified in this manual.

### 4.6.3 - OPERATION

HSDIM11 is an intruder detector that signals the movement of people in the protected area. In order not to waste the batteries the detector is fitted with a standby function; does not send out any other signal after the first alarm signal if there is no further movement for at least 2 minutes (except when the battery compartment is open).

• **Second alarm:** the HSDIM11 can be programmed to transmit 2 different alarms (transmission of 2 different codes): one for movement detection and one for the NC contact or pulse counter.

• **Supervision:** transmission of a signal every 40 minutes to indicate that the system is running.

• **Anti-opening protection:** the opening of the battery compartment and/or separation of the device from the surface on which it is fixed triggers the "tampering" alarm. To avoid this set the control unit to "TEST" mode before opening the sensor.

• **External LED:**

- when the LED comes on for 1 second it indicates that there has been an alarm signal;
- after the alarm signal, if the LED flashes quickly 4 times it means that the battery is almost discharged.

Replace the battery only when the control unit indicates that the detector has a discharged battery. To replace the battery see the instruction manual of the HSDIM11.

### 4.6.4 - INSTALLATION

For installation operations see the instruction manual of the HSDIM11. **Caution! - The sensor may be installed a heights over 1.5 m but only using the optional joint (fig. 23) to ensure efficient detection of intruders.**

### 4.6.5 - PROGRAMMING OF DIP SWITCHES

**Caution! - To program the "dip-switches" remove the battery from the device; remove the battery also to make any changes and then reprogram.**

Dip-switch functions (fig. 24):

- 1 OFF = sensitivity: for range of about 5 m.
- 1 ON = sensitivity: for range of about 10 m.

- 2 OFF = non-differentiated alarm signal: transmission of single code for both alarms.
- 2 ON = differentiated alarm signal: transmission of 2 different codes, one for the detector alarm and one for the alarm of the NC input.

- 3 OFF = immediate alarm signal of opening of NC input.
- 3 ON = alarm signal after 6 pulses on NC input.

- 4 OFF = alarm signal when movement of the intruder is first detected.
- 4 ON = alarm signal when movement of the intruder has been detected twice.

5\* OFF = Anti-removal/tamper protection **enabled**.

5\* ON = Anti-removal/tamper protection **disabled** (to be used when fixed on irregular or unstable surfaces)

6\* = Not used.

(\* available from April 2010).

### 4.6.6 - CONNECTION OF EXTERNAL DEVICES

To connect external sensors using wires to the NC contacts see **fig. 25**. With dip-switch 3 set to "ON" the input is suitable to control rolling shutter detectors or inertia sensors where the alarm is signalled after 6 pulses in 30 seconds.

The NC input is automatically activated by closing the contact for about 10 seconds after inserting the battery.

To memorise the detector in the control unit see **chapter 6.2.4**.

If the NC input on the terminal board is used and a differentiated alarm is required, the following memorisation steps must be carried out:

- at first leave the dip switch N° 2 = OFF (non-differentiated alarm)
- set the control unit for the memorisation of the first code (infrared detector); then insert the battery to carry out memorisation
- set the control unit for the memorisation of the second code (NC input); then move the dip switch N° 2 = ON when requested to "insert battery in detector".

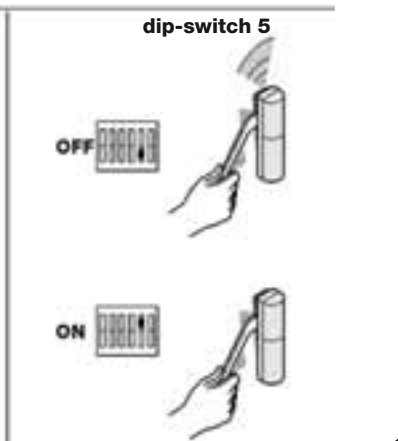
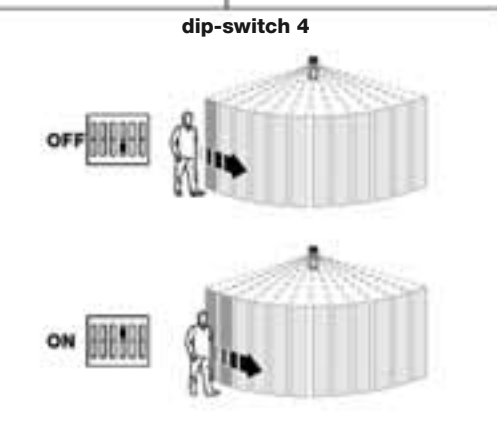
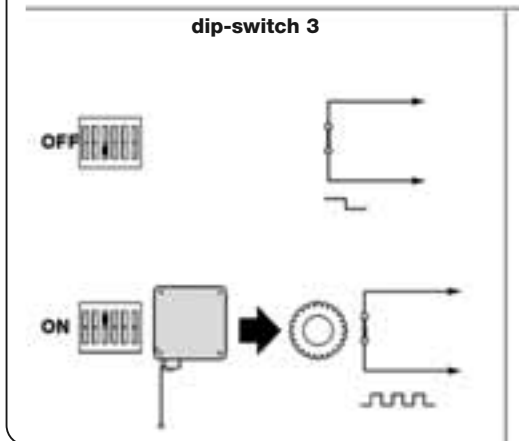
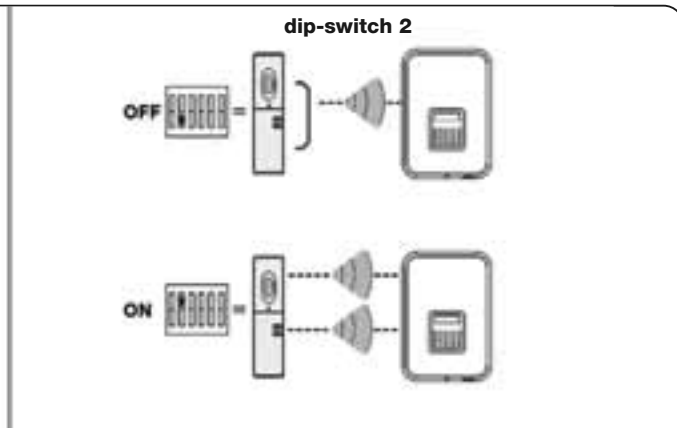
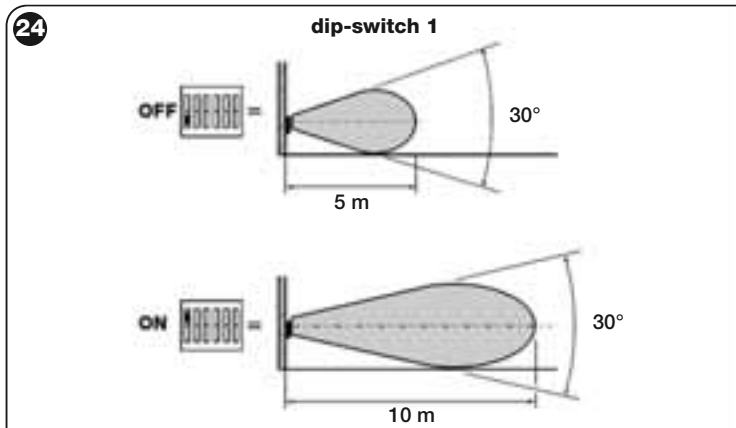
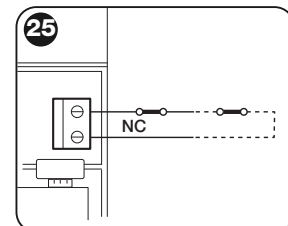
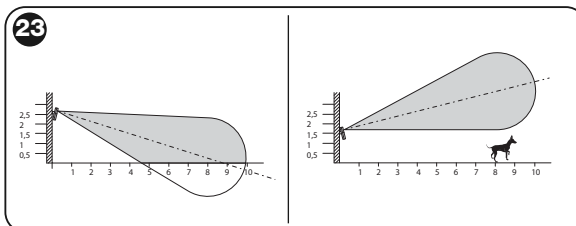
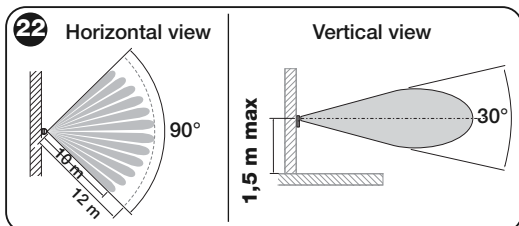

## 4.7 - Infrared detector with vertical curtain lens (model HSDIM12)

### 4.7.1 - SPECIAL WARNINGS

- To avoid intentional damage, install the product in a position that is difficult to reach.
- Do not install the product near possible hot or cold air turbulences or where there are animals (hot blooded); if necessary reduce the sensitivity of the sensor.

### 4.7.2 - PRODUCT DESCRIPTION AND INTENDED USE

HSDIM12 is an infrared detector with vertical curtain lens for use in protected indoor and outdoor areas; designed to protect access areas (doors/windows). It detects the movement of an intruder in the protected area and transmits it via radio to the associated control unit. Any other use is to be considered improper and prohibited! Nice declines all liability for damage resulting from improper use of the product and any use other than as specified in this manual.

### 4.7.3 - OPERATION

HSDIM12 is a perimeter protection detector for doors and windows; thanks to its curtain lens it signals the movement of persons present only within the close range in front of the sensor.

To increase protection it is fitted with a second input for NC type contact which can be used to connect another sensor, also pulse type (detector for rolling shutters); the alarm can be single or differentiated for the two different detections. It contains anti-tampering and anti-break-in detectors.

Communication is completely via radio with dual band technology; battery operated - standard 9V.

Equipped with LED indicator visible from the outside.

#### Types of alarm signal:

- **Intruder alarm:** alarm signal caused by the detection of movement in the protected area. In order not to waste the batteries the detector does not send out any other signal after the first alarm signal if there is no further movement for at least 3 minutes (except when the battery compartment is open).
- **Second alarm:** the HSDIM12 can be programmed to transmit 2 different alarms (transmission of 2 different codes): one for movement detection and one for the NC contact.
- **Supervision:** transmission of a signal every 40 minutes to indicate that the system is running.
- **Anti-opening protection:** the opening of the battery compartment and/or separation of the device from the surface on which it is fixed triggers the "tampering" alarm. To avoid this set the control unit to "TEST" mode before opening the sensor.
- **External LED:**
  - when the LED comes on for 1 second it indicates that there has been an alarm signal;
  - after the alarm signal, if the LED flashes quickly 4 times it means that the battery is almost discharged

Replace the battery only when the control unit indicates that the detector has a discharged battery. To replace the battery see the instruction manual of the HSDIM12.

### 4.7.4 - INSTALLATION

For installation operations see the instruction manual of the HSDIM12.

### 4.7.5 - PROGRAMMING OF DIP SWITCHES

**IMPORTANT!** - The "dip-switches" must be programmed before powering the device. Also disconnect the battery to make any modifications and then reprogram.

See fig. 26:

**1 OFF** = sensitivity: for range of about 3 m.

**1 ON** = sensitivity: for range of about 6 m.

**2 OFF** = **non-differentiated** alarm signal: transmission of single code for both alarms.

**2 ON** = **differentiated** alarm signal: transmission of 2 different codes, one for the detector alarm and one for the alarm of the NC input.

**3 OFF** = **immediate** alarm signal of opening of NC input.

**3 ON** = alarm signal **after 6 pulses** on NC input.

**4 OFF** = input in use, NC contact connection necessary.

**4 ON** = input not in use (factory setting); the input is closed by the dip-switch.

**5\* OFF** = Anti-removal/tamper protection **enabled**.

**5\* ON** = Anti-removal/tamper protection **disabled** (to be used when fixed on irregular or unstable surfaces)

**6\*** = Not used.

(\* available from April 2010).

### 4.7.6 - CONNECTION OF EXTERNAL DEVICES

To connect external sensors using wires to the NC contacts see fig. 25. With dip-switch 3 set to "ON" the input is suitable to control rolling shutter detectors or inertia sensors where the alarm is signalled after 6 pulses in 30 seconds.

**To memorise the detector in the control unit see chapter 6.2.4.**

If the NC input on the terminal board is used and a differentiated alarm is required the following memorisation steps must be carried out:

- at first leave the dip switch N° 2 = OFF (non-differentiated alarm)
- set the control unit for the memorisation of the first code (infrared detector); then insert the battery to carry out memorisation
- set the control unit for memorisation of the second code (NC input); then move the dip switch N° 2 = ON when requested to "insert battery in detector".

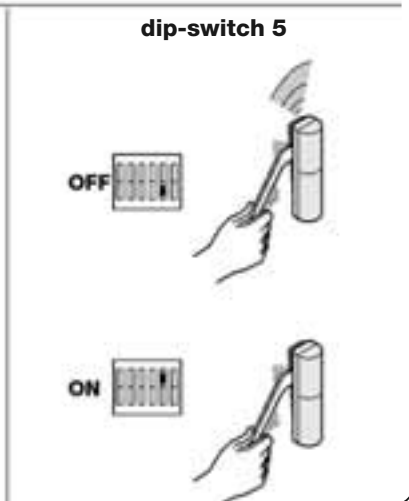
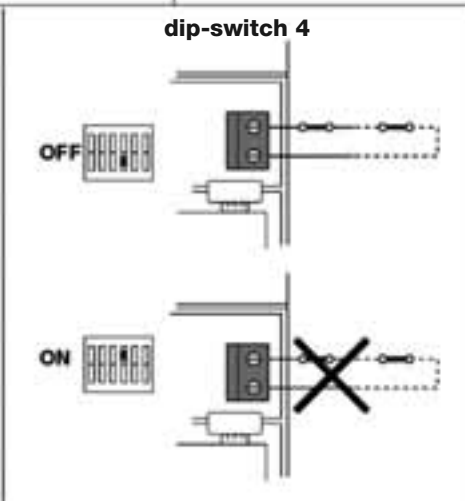
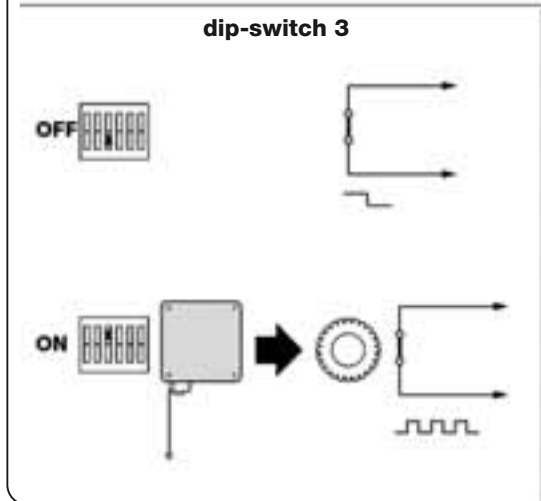
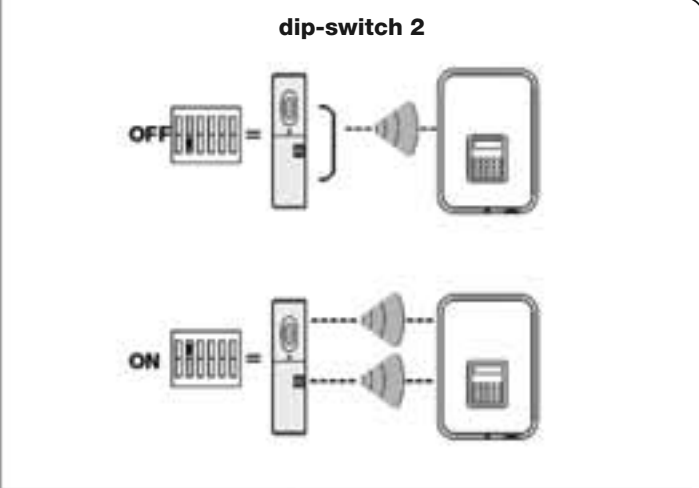
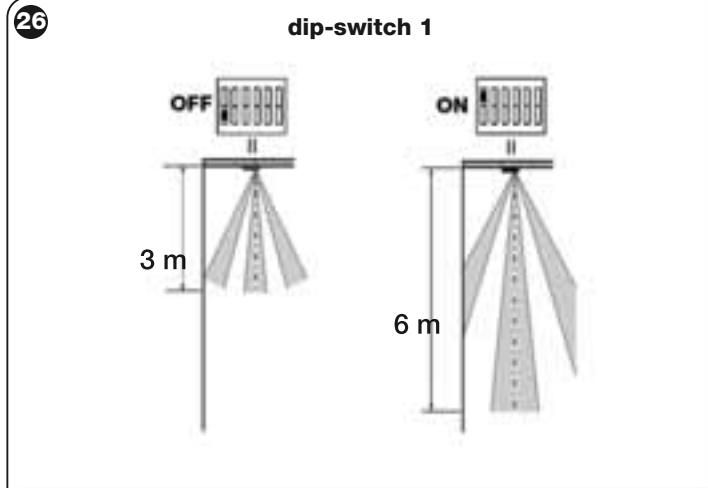
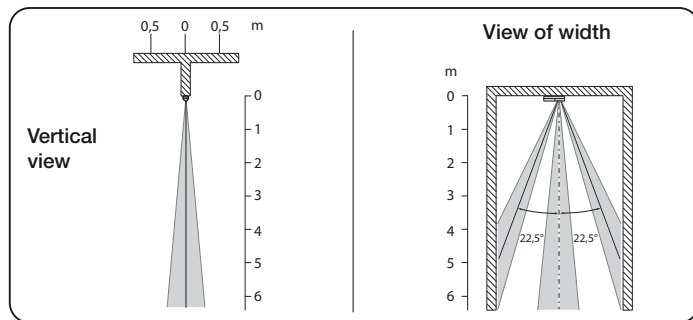



#### 4.8 - Acoustic detector of glass breakage (model HSDID01)

##### 4.8.1 - SPECIAL WARNINGS

- To ensure optimal detection, the device must be installed in rooms with an area of 20 to 30 square metres, at a distance of 3 to 6 m from the glass to be protected and at a height of approx. 2 m (fig. 27).
- **Installation is not recommended:** in areas with dimensions of less than 3 x 3 m, in excessively humid environments (bathrooms or kitchens) or in garages with large metal doors. These situations may generate improper alarms.
- Battery lifetime is reduced if the detector is placed in very noisy areas due to the continuous signalling of noise.

##### 4.8.2 - PRODUCT DESCRIPTION AND INTENDED USE

HSDID01 is a detector of glass breakage; suitable for indoor use. Any other use is to be considered improper and prohibited! Nice declines all liability for damage resulting from improper use of the product and any use other than as specified in this manual.

##### 4.8.3 - OPERATION

HSDID01 is a sensor suitable to detect glass breakage; suitable for normal glass, double glazing or security glazing. The detector is equipped with a microphone calibrated to recognise the sound of breaking glass. It must be used with a great deal of attention because it may also detect a china cup that falls on the floor; the sensor should only be activated when there is no risk of other sounds that may trigger the alarm.

Also appliances able to generate sudden pressure surges in rooms (air conditioners, fans) may generate improper alarms.

Sound-absorbing materials (such as curtains and carpets) may reduce sensitivity of the device.

The device is optimised with factory-setting and may not be modified.

It contains an anti-tampering detector.

Communication is completely via radio with dual band technology; battery operated - 9 V standard

Equipped with LED indicator visible from the outside.

##### Types of alarm signal:

- **Noise signal (test):** by producing a sudden noise in front of the detector (clapping hands or knocking two metal objects together) the led should flash briefly twice. These noises do not trigger the alarm. **Caution!** - If the LED does not flash after the noise test the battery may be discharged or the device may be faulty.
- **Alarm status:** the breakage of glass (an old bottle can be broken for testing) generates the transmission via radio of the alarm signal and makes the LED switch on for 4 seconds. The LED flashes for about one minute after the alarm;
- **Anti-opening protection:** The opening of the casing triggers the "tampering" alarm signal. To avoid this problem, set the control unit to "TEST" mode before opening the sensor.
- **Battery discharged:** The low battery signal is transmitted to the control unit a few days in advance. Replace the battery only when the control unit indicates that the detector has a discharged battery. To replace the battery see the instruction manual of the HSDID01.
- **Supervision:** transmission of a signal every 40 minutes to indicate that the system is running.

##### 4.8.4 - INSTALLATION

For installation operations see the instruction manual of the HSDID01.

##### 4.8.5 - PROGRAMMING

HSDID01 does not require any adjustments or programming.

To memorise the detector in the control unit see chapter 6.2.4.



#### 4.9 - Fine combustion powder detector (model HSDIS01)

##### 4.9.1 - SPECIAL WARNINGS

**Caution!** - The detector must not be considered a total protection but simply a support in the protection against combustion risks. The device is not a fire detector and does not comply with any regulations on fire detection.

- The alarm signal emitted by the detector may not be heard by people with hearing problems or under the effect of alcohol or drugs.
- Install the product in a position that is difficult to reach to avoid any damage.
- Do not modify sensitivity of the detector.
- The detector must not be painted or varnished.
- Battery lifetime is reduced in the event of frequent alarm signals.
- The detector may not function correctly if the batteries are discharged.
- To clean the surface of the detector use a soft, slightly damp cloth; do not use products that contain alcohol, benzene, diluents or similar. Do not dust with feather dusters.
- The device must be replaced after 10 years of use; within 2-3 years if installed in particularly dusty areas.

##### 4.9.2 - PRODUCT DESCRIPTION AND INTENDED USE

HSDIS01 is a fine combustion powder detector (mist or smoke effect); suitable for indoor use. Any other use is to be considered improper and prohibited!

Nice declines all liability for damage resulting from improper use of the product and any use other than as specified in this manual.

##### 4.9.3 - OPERATION

HSDIS01 is a fine combustion powder detector (mist or smoke effect) designed for residential applications. A photodiode detects opacity of the air and signals the alarm directly on site (by means of a buzzer) and also via radio to the control unit. The detection technology used is of the photo-optical type and does not emit any type of harmful radiations.

It is suitable to control an area of up to 6 x 6 m; it should be installed on the ceiling at the centre of the area. Smaller rooms that are not square, such as corridors, require the use of more than one detector.

Communication is completely via radio with dual band technology; battery operated - 9 V standard.

Equipped with LED indicator visible from the outside and buzzer for audible signals.

##### Types of alarm signal:

- **Normal operation (self-diagnosis):** LED flashes briefly every 45 seconds;
- **Alarm status:** the concentration of combustion powders in the environment generates transmission of the alarm signal via radio, continuous flashing of the external LED and continuous sounding of the buzzer. The alarm status ends when the situation ends;
- **Presence of heavy powders inside the sensor:** short acoustic tone every 45 seconds and flashing of the external LED not synchronised with the acoustic tone. This alarm status ends once the powder has been removed (this operation must be carried out by the technical assistance service);
- **Battery almost discharged:** short acoustic tone every 45 seconds and flashing of the external LED synchronised with the acoustic tone.  
Replace the battery only when the control unit indicates that the detector has a discharged battery. To replace the battery see the instruction manual of the HSDIS01.  
The battery can be replaced by opening the sensor; this does not generate alarms (the detector does not have a tampering sensor)
- **Supervision:** transmission of a signal every 40 minutes to indicate that the system is running.

##### 4.9.4 - INSTALLATION

For installation operations see the instruction manual of the HSDIS01.

##### 4.9.5 - PROGRAMMING

HSDIS01 does not require any adjustments or programming.

To memorise the detector in the control unit see chapter 6.2.4. Memorisation is usually carried out in the zone of the technical alarms.

##### 4.9.6 - TEST

The detector is equipped with a test button to verify efficient operation of the detector. Press the button for about 1 second to test the sensor; if it is in good working order the LED should flash, the buzzer should emit acoustic tones and the alarm signal should be transmitted.

To guarantee adequate safety levels, the test should be carried out at least once a month.

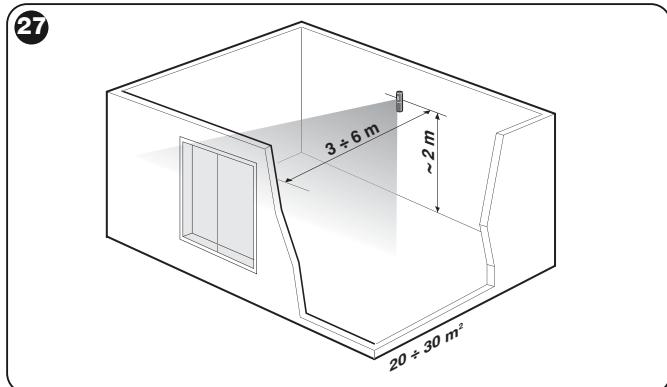



## 4.10 - Flooding detector (model HSDIW01)

### 4.10.1 - SPECIAL WARNINGS

- To obtain optimal detection, the device must be installed vertically on the wall and flush with the ground surface.
- The sensor should be installed in a location most subject to the risk of water leaks, but if the floor is not level, it should be placed at the lowest point of the room.
- The sensor is connected to the NO input of one of the compatible detectors (for example HSDID11). The cable length must not exceed 10 m. Multiple sensors may be connected in parallel on the same input of the detector.

### 4.10.2 - PRODUCT DESCRIPTION AND INTENDED USE

HSDIW01 is a flooding detector destined for use in alarm systems for indoor application. Any other use is to be considered improper and is strictly prohibited! Nice declines all liability for damage resulting from improper use of the product and other than as specified in this manual.

### 4.10.3 - OPERATION

The sensor comprises 2 electric contacts placed at approx. 1 mm from the floor. In the event of a flood, when the sensor comes into contact with liquid, the event is immediately read by the detector connected to HSDIW01 by a cable; this then transmits the emergency signal to the control unit via radio.

#### Types of alarm signal:

HSDIW01 does not emit any signal.

### 4.10.4 - INSTALLATION

For installation procedures, refer to the HSDIW01 instruction manual.

### 4.10.5 - PROGRAMMING

HSDIW01 does not require any adjustments or programming. Programming of a differentiated alarm is recommended on the detector connected to the sensor; in this way the flooding alarm can be distinguished from other types of alarm.

## 4.11 - 4-channel alarm transmitter (model HSTX4)

### 4.11.1 - PRODUCT DESCRIPTION AND INTENDED USE

HSTX4 is a bidirectional keypad with 64 bit variable code (rolling code); it enables the activation and deactivation of alarm control units, and receives operation confirmation signals from the latter; otherwise it can be used to control other receivers in the system. Designed for indoor use.

Any other use is to be considered improper and is strictly prohibited! Nice declines all liability for damage resulting from improper use of the product and other than as specified in this manual.

### 4.11.2 - OPERATION

HSTX4 is fitted with 4 keys; each one is normally assigned with a specific function:

**x** = Key (off): total deactivation

**y** = Key (on): total activation

**z** = Key (partial): partial activation (zones A+B)

**w** = Key (panic): command key (panic, illness or burglar alarm or receiver control)

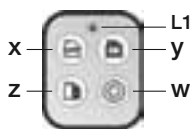

The assigned function on keys (partial) and (panic) can be changed, for example key (partial) can be used as a command key or key (panic) may be used as a second partial activation key (zones B+C); to change the assigned function refer to the paragraph "programming".

### 4.11.3 - PROGRAMMING

The transmitter is programmed via the control unit and on the receivers to be associated.

Further information on the memorisation procedure can be found in the instructions of the relative products.

#### • Programming the transmitter on the control unit:

- Set the control unit to remote control programming mode and perform the preliminary phases required (see chapter 6.2.4.1);

- When the control panel menu displays the request: on the transmitter, press and hold the keys (off) and (on) simultaneously for 10 seconds; the control panel then emits a beep to confirm programming. This programming procedure memorises the key (on) for total arming, key (off) for disarming and (partial) for partial arming.

Key (panic) is not memorised and is left free for alarm control (panic or robbery) or to control receivers.

#### • Programming the key (panic) on the control panel to send "panic" or "robbery" alarms:

- Set the control panel to programming mode in the zone "Panic" or "Robbery2" (see chapter 6.2.4.5) according to the type of alarm to be activated.

- When the control panel menu displays the request: on the transmitter, press and hold

the key (panic) for 10 seconds; the control panel then emits a beep to confirm programming.

#### • Programming the key (panic) (or (partial)) to control a receiver:

- Set up the receiver for radio code memorisation (see specific instructions); when required, press and hold key (panic) for 10 seconds.

If required, the factory set function of keys (partial) and (panic) can be changed.

- **To change the function of key (partial)** from partial arming (zones A+B) to control key: press and hold keys (off) and (partial) for 10 seconds; the led emits 3 short orange flashes to confirm conversion from the partial activation function to the command key function.

- **To change the function of key (panic)** from command key to partial arming (zones B+C) press and hold keys (off) and (panic) for 10 seconds; the led emits 2 short orange flashes to confirm conversion from the command key function to the partial arming function. The functions can be changed in the other direction simply by repeating the operation. On completion, the led emits 2 short flashes if the key is assigned for partial activation or 3 short flashes if it is assigned as a command key.

The zones partially armed by means of keys (partial) (partial A+B) and (panic) (partial B+C) are not modifiable and depend on the fact that these zones are included during memorisation of the remote control (keys OFF and ON). The keys for partial activation do not require a specific memorisation procedure as this is performed at the same time as that of keys (off) and (on); while keys (partial) and (panic) need to be memorised specifically if used to control alarms (panic or robbery) or to control receivers.

### 4.11.4 - SIGNALS

The transmitter is bidirectional; after sending the activation or deactivation commands, partial or total (phase in which the orange led is illuminated) it remains on standby for response by the control unit (phase in which the orange led flashes), after which the result is displayed as follows:

**Green led lit for 2 seconds:** OFF, system deactivated

**Red led lit for 2 seconds:** ON, system activated (total or partial)

**Led off:** response not received

The command keys do not have a response standby setting; after sending the command the led turns off immediately.

When the battery charge is low, the transmitter range is reduced significantly. When a key is pressed, if led L1 illuminates and then immediately fades and turns off, this means that the battery is completely discharged and must be replaced immediately.

Otherwise if led L1 illuminates briefly and then turns off, this means that the battery is only partially discharged; in this case press and hold the key for at least half a second to enable the transmitter to attempt delivery of the command and wait for the response. In any event, if the battery charge is too low to complete an operation, the led fades and the transmitter turns off.

When the battery is discharged, the battery must be replaced with the same version to restore normal transmitter operation.

To replace the battery, refer to the HSTX4 instruction manual.

## 4.12 - 8-channel radio transmitter (model HSTX8)

### 4.12.1 - PRODUCT DESCRIPTION AND INTENDED USE

HSTX8, is a bidirectional radio transmitter with variable code (rolling-code) and 8 channels; 4 for alarm systems and 4 for direct control of receivers and automations for doors and gates. Designed for indoor use. Any other use is to be considered improper and is strictly prohibited! Nice declines all liability for damage resulting from improper use of the product and other than as specified in this manual.

### 4.12.2 - OPERATION

HSTX8 is a radio transmitter with 8 channels divided into two groups of 4 channels; for the first 4 keys, encoding is compatible with the "Nice Home Security" systems, while the other 4 keys have "O-Code" encoding, Nice-One compatible, used for the control of automations of doors, gates and similar products.

For the first 4 keys, the functions and operation are identical to those of the transmitter HSTX4; for details refer to the relative instructions.

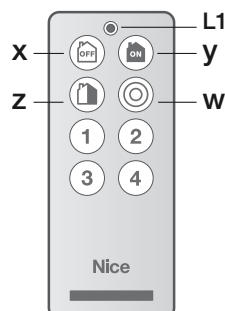

The other 4 keys (1-2-3-4) use a transmission technology called "O-Code", with variable code (rolling-code), which significantly improves

the command transmission speed and enables a series of evolved functions typical of the system Nice-Opera.

For further information on all functions of the system NiceOpera and operative interdependency of the various system devices, refer to the general manual "NiceOpera System Book", also available on the web site [www.niceforyou.com](http://www.niceforyou.com)

Further information can also be found in the specific instruction manual of HSTX8.



## 4.13 - Control keypad (model HSKPS)

### 4.13.1 - SPECIAL WARNINGS

Install the product in an easily accessible location (for example close to the main entrance).

### 4.13.2 - PRODUCT DESCRIPTION AND INTENDED USE

HSKPS is a bidirectional dual band keypad that enables the activation and deactivation of alarm control units, and receives operation confirmation signals from the control unit; otherwise it can be used to control other receivers in the system. Designed for indoor use.

Any other use is to be considered improper and is strictly prohibited! Nice declines all liability for damage resulting from improper use of the product and other than as specified in this manual.

### 4.13.3 - OPERATION

Enables total or partial activation or deactivation of the control panel using the 5-digit codes programmed on the panel (N.B. the user code and installer code are not accepted). Maximum transmission security is guaranteed thanks to encrypting using a Rolling Code system. The keypad can transmit other commands via radio to the control panel or to specific receivers for automations. An internal buzzer confirms manoeuvres and emits audible signals when new events are present in the control panel memory. A low battery signal is also incorporated.

HSKPS can be wall-mounted or used in the tabletop version (with the special rubber support mod. HSKCT - optional accessory).

### Description of leds and keys

There are 8 indicator leds, 10 numerical keys and 10 function keys (fig. 28):

- |  |
|--|
| 1 = A, B, C zone leds: lit when the zone is active   |
| 2 = Led (📡): transmission; lit when a radio signal is transmitted  |
| 3 = Led (🚨): warning – new event; lit when the control unit is deactivated, to signal a new event  |
| 4 = Led (🚪): warning – door open; lit when the control unit is activated and a door or window has been left open   |
| 5 = Led (🔋): warning – battery charge low; lit when the control unit is activated or deactivated to indicate that the battery charge is low and batteries need to be replaced                      |
| 6 = Led (⌘): lit during standby for confirmation of a control unit command   |
| 7 = Keys (P1), (P2) and (🚨): keys for direct radio commands (no code entry required) to activate specific functions or to control radio receivers, e.g. HSTT2L (see: "Use as general transmitter") |
| 8 = Key (ESC): reset key, used to delete a code entered incorrectly  |
| 9 = Keys (A), (B) and (C): used to select the zones to be activated or deactivated (A, B, and C)   |
| 10 = Key (📡): used to send an activation command to the control unit   |
| 11 = Key (🔌): used to send a deactivation command to the control unit  |
| 12 = Key (?): used to send a query command to the control unit   |
| 13 = Keys "0 - 9": numerical keys used to enter the code to send to the control unit or receivers associated with HSKPS.   |

### Functions available and relative signals

#### Control unit activation/deactivation:

- **Total activation:** enter the personal 5-digit code and after entry of the fifth digit, leds "A - B - C" illuminate, after which press the red key (📡). Entry is confirmed by the emission of 3 beeps and leds A - B - C remain lit for 30 seconds.

- **Partial activation:** enter the personal 5-digit code and after entry of the fifth digit, leds (A - B - C) illuminate. Press keys (A), (B) or (C) of the zones not to be activated; the relative leds turn off. Now press the red key (📡);

- **Deactivation:** enter the personal 5-digit code and after entry of the fifth digit, leds "A - B - C" illuminate, after which press the green key (🔌). Deactivation is confirmed by the emission of 1 beep and leds A - B - C remain off. **Note** – Deactivation is always total, even if keys (A), (B) or (C) are pressed to turn off specific zone leds.

- **Deactivation under force (anti-duress):** If one or more anti-duress codes have been programmed on the control unit, as an alternative to entry of the personal 5-digit code, this specific 5-digit code can be entered, which, as well as deactivating the control unit also makes telephone calls to request assistance as envisaged for this function (see chapter 6.2.4.2).

• **Code entry errors:** if an incorrect code is entered, press the key (ESC) to reset and enter the correct version.

• **Incorrect code:** if an incorrect code is used (code not memorised) led (📡) flashes 8 times, and during this interval led (⌘) remains lit. After 8 attempts with an incorrect code, all leds start flashing, and the control unit remains blocked for 30 seconds.

• **Control unit status check:** press the key (?) to query the control unit; after a brief interval the leds (A, B, C) illuminate according to the zones activated; if no led turns on, this means that the control unit is deactivated.

• **Use as general transmitter:** as well as the normal control unit activation and deactivation functions, the keypad can be used as a transmitter for direct control of specific functions or to activate receivers.

- (P1) is a direct command key; if memorised on the receivers (e.g. HSTT2L) it transmits an ON and OFF command (toggle) each time it is pressed.

- (P2) is a direct command key; if memorised on the receivers (e.g. HSTT2L) it transmits a command (pulse) each time it is pressed.

- (🚨) is a direct command key; it is normally memorised on the control unit as a "panic" or "burglar" alarm activation key, but can also be memorised on the receivers (e.g. HSTT2L) to transmit a command (pulse) each time it is pressed. **Caution!** – Transmission occurs after the key has been pressed for 2 seconds.

- By pressing the numerical keys, for example 25, followed by keys (📡) and (🔌) activation (📡) and deactivation (🔌) commands can be sent respectively to the corresponding receiver memorised with the code 25 (e.g. HSTT2L).

### 4.13.4 - INSTALLATION

For installation procedures, refer to the relative instruction manual.

### 4.13.5 - PROGRAMMING

The keypad is programmed via the control unit and on the receivers to be associated. Further information on the memorisation procedure can be found in the instructions of the relative products.

#### Programming the keypad on the control unit (to use the 5-digit code for activation/deactivation):

- insert the batteries (remove the separation tab) on the keypad; a beep is emitted and all leds flash for 60 seconds.

- Within this interval, the control unit must be activated and then deactivated (with any other device enabled); on deactivation, 6 beeps are emitted to confirm memorisation of the keypad on the control unit.

This operation must be performed each time the keypad batteries are changed.

#### Programming the key (🚨) to send "panic" or "burglar" alarms:

- set the control unit to programming mode in the zone "Panic" or "Burglar" (see chapter 6.2.4.5) according to the type of alarm to be activated.

- when the control unit menu displays the request: on the keypad, press and hold the panic key (🚨) for 10 seconds; the control unit then emits a beep to confirm programming.

This programming also activates the tampering alarm via the keypad. If the key (🚨) is not memorised, this alarm is not activated.

#### Programming keys (P1) and (P2):

- to activate, set the receiver (or control unit) to memorise the radio code (see specific instructions).

- when requested, press and hold the key for 10 seconds.

#### Programming the numerical keys to send commands (📡) - (🔌):

- set up the receiver for radio code memorisation (see specific instructions); when required, enter the numerical code on the keypad e.g. [25] then press and at the same time hold keys (📡) and (🔌) for at least 1 second.

Radio codes from 1 to 9999 can be used to control the corresponding number of receivers.

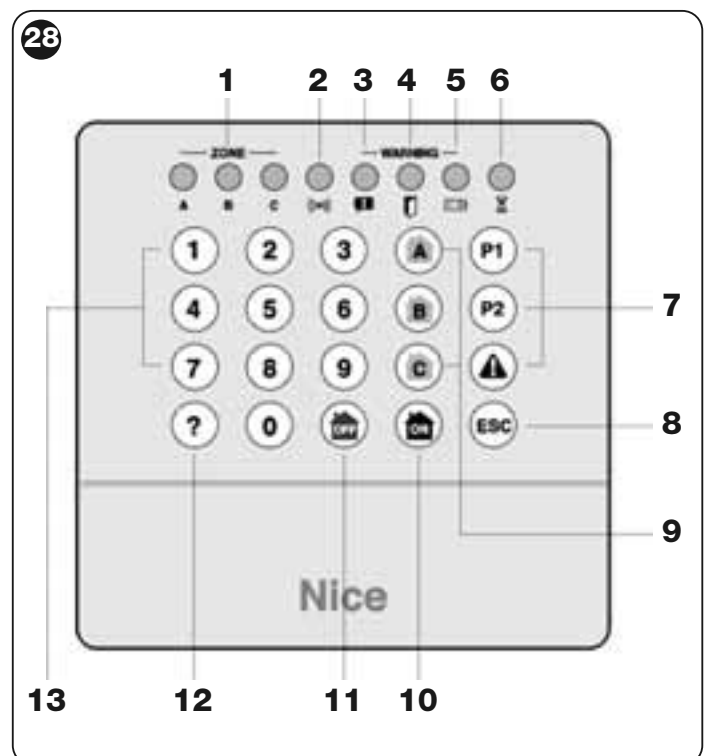



## 4.14 - Outdoor siren via radio (model HSSO1)

### 4.14.1 - SPECIAL WARNINGS

Install the product in a location difficult to reach, to avoid intentional damage, possibly in a location where the sound produced can be propagated efficiently in the required directions. If necessary, fit additional sirens. *Note - HSSO1 is compatible with the nice home system control panels with firmware version J onwards.*

### 4.14.2 - PRODUCT DESCRIPTION AND INTENDED USE

HSSO1 is an outdoor siren via radio with sound power of 116 dB; designed to signal intrusion and also to dissuade intruders. Powered by a battery pack, the control via radio is bidirectional and dual band; suitable for outdoor use.

Any other use is to be considered improper and is strictly prohibited! Nice declines all liability for damage resulting from improper use of the product and other than as specified in this manual.

### 4.14.3 - OPERATION

HSSO1 signals intrusion with a powerful acoustic alarm or a specially recorded voice message. On each alarm command sent by the control panel, it emits an alarm signal lasting maximum 3 minutes (approx.); the alarm signal terminates when the control panel is disarmed. Thanks to a special voice function, two specific messages can be recorded on HSSO1:

**1) Voice message 1 (MSG1):** replaces the siren pre-alarm beeps. This lasts a maximum of 10 seconds after which the high power siren is activated for 3 minutes.

**2) Voice message 2 (MSG2):** replaces the siren sound each time an "external" alarm is activated. This lasts a maximum of 20 seconds, repeated for 3 minutes.

To obtain an "external" alarm, this function must be enabled on the control panel, in the required zone (e.g. ZONE A) select external alarm Y=yes. All detectors in this zone generate "external" alarms and are therefore voice only.

If the siren housing is opened (without first setting the associated control panel to TEST mode) an alarm signal is activated for approx. 3 minutes. The tamper alarm is also sent to the control panel.

HSSO1 receives the signal on system status from the control panel and emits visual and audible signals (flashes) according to the specific status.

#### Segnals:

- 3 beeps and 3 flashes = confirms arming of the control panel
  - 1 beep and 1 flash = confirms disarming of the control panel
  - series of beeps with lamp lit, for approx. 12 seconds; delay before alarm.
  - continuous ring with lamp lit, for approx. 2 seconds: control panel in "TEST" mode; in this case the siren can be opened without activating the tamper alarm.
  - rapid series of beeps and flashes for approx. 30 seconds on arming and disarming of the control panel = batteries discharged
- On activation of the battery discharged signal, the batteries must be replaced as soon as possible. Incorrect alarm signals may be generated when batteries are discharged.
- Voice messages

### 4.14.4 - INSTALLATION

For installation procedures, refer to the relative instruction manual.

**Caution!** - In areas subject to vibrations, the "intruder protection" must be disabled (enabled on factory settings) by moving the electric jumper "shock" and positioning it as shown in the detail of **fig. 30**, on OFF.

### 4.14.5 - PROGRAMMING

The following 3 phases must be performed to complete programming.

#### 1. Memorising the radio code of siren HSSO1 on the control panel

This operation enables the control panel to receive signals for the tamper alarm, low battery status and supervision signal (approx. every 40 minutes).

To memorise this code:

- 01.** Set up any zone (A, B, or C) for acquisition of a radio device
- 02.** Activate the "external" alarm function (Y=yes) only if voice type alarms are required
- 03.** Insert the battery connectors when requested by the control panel; leds MSG1 and MSG2 flash briefly and the code is sent to the control panel
- 04.** Complete the memorisation procedure by entering the siren name.

#### 2. Recording voice messages (OPTIONAL)

• **Select a message:**

- 01.** Press **SELECT** once or more to select a message (MSG 1 or MSG 2 - **fig. 30**): Flashing Led = message not present; Led lit = message already recorded;

• **Record a new message (only if led is flashing):**

- 01.** Select, and within 10 seconds, press and hold **REC (fig. 30)**.
- 02.** Then record the message speaking with a normal voice at approx. 40-50 cm from the microphone.
- 03.** Release **REC** at the end of recording (the message will then be played automatically).

• **Listening to the selected message (only if led is lit):**

- 01.** Select, and within 10 seconds, press **PLAY (fig. 30)**.

• **Deleting the selected message (only if led is lit):**

- 01.** Select, and within 10 seconds, press and hold **ERASE (fig. 30)** until the relative led turns off.

Before closing the housing the volume of the messages and beeps can be adjusted as required:

- 01.** Turn the BEEP potentiometer (**fig. 30**) to modify the volume of the beeps.
- 02.** Turn the MSG potentiometer (**fig. 30**) to modify the volume of the voice messages.

#### 3. Memorising the radio code of the control panel on the siren HSSO1

This operation enables the siren to receive and perform alarm commands sent from the control panel.

- 01.** Close the siren housing; a beep and short flash confirm perfect closure of the anti-tamper contacts.
- 02.** Immediately afterwards, activate and deactivate the alarm; the siren confirms programming with 6 beeps and 6 flashes.

When an association is made, the siren always remains associated with the relative control panel. If the siren needs to be moved from one system to another, proceed as follows:

- 01.** Remove the batteries.
- 02.** Press and hold **ERASE**
- 03.** Insert the batteries and wait for a few seconds.

30

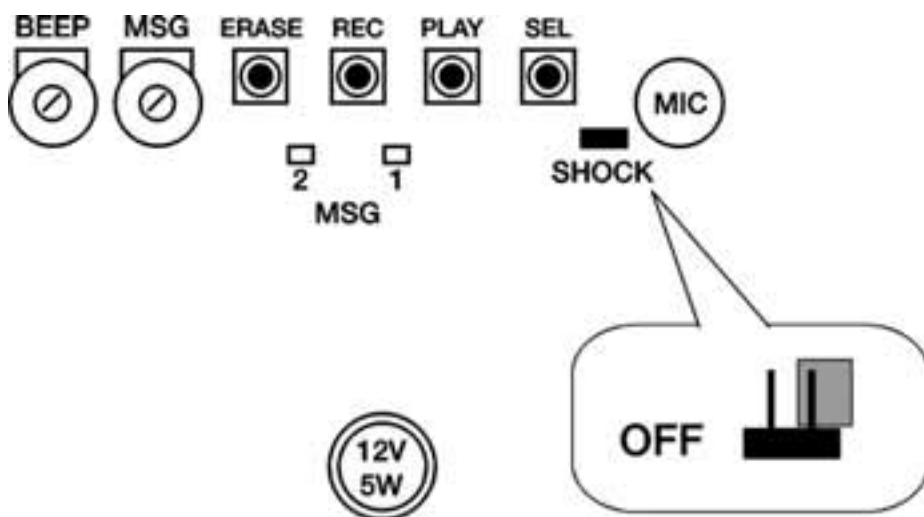



## 4.15 - Outdoor siren, wired (model HSSOC)

### 4.15.1 - SPECIAL WARNINGS

Install the product in a location difficult to reach, to avoid intentional damage, possibly in a location where the sound produced can be propagated efficiently in the required directions. If necessary, fit additional sirens.

### 4.15.2 - PRODUCT DESCRIPTION AND INTENDED USE

HSSOC is an outdoor wired siren with a sound power of 116 dB; designed to signal intrusion and also to dissuade intruders.

Powered by the control panel, it envisages a backup battery (12 V 2,2 Ah) also for operation in the event of a power failure; suitable for outdoor use.

Any other use is to be considered improper and is strictly prohibited! Nice declines all liability for damage resulting from improper use of the product and other than as specified in this manual.

### 4.15.3 - INSTALLATION

For installation procedures, refer to the relative instruction manual.

### 4.15.4 - PROGRAMMING

HSSOC does not require special programming. However, 2 settings are required before marking the electrical connections:

- T/C block command:** positive (+) or negative (-); for control panels HSCU1C and HSCU1GC leave setting on +.
- Alarm signal block:** after 3 or 5 alarm cycles.

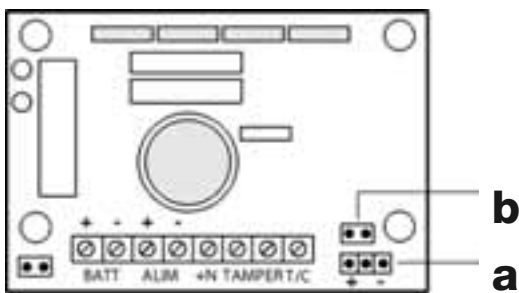

### 4.15.5 - ELECTRICAL CONNECTION TO CONTROL PANEL

To make the electrical connection to the control panel, refer also to chapter 5 in this instruction manual.

**BATT +/-:** electrical connection to backup battery. The back-up battery Pb-12V 2.2Ah (not supplied) is indispensable for siren operation.

**P.SUPPLY +/-:** electrical power supply connection from control panel ( P.SUPPLY - = GND; P.SUPPLY + = +SAA)

**+ N:** positive "on absence" which activates the alarm (if block is not present on T/C).

**TAMPER:** output (voltage-free contact) for tampering alarm, for tamper alarm input connection on control panel (between GND and TMP A or B or C). Otherwise the tamper contact can be connected in series to + N.

**T/C:** block command, for connection to control panel armed/disarmed signal (+OFF).

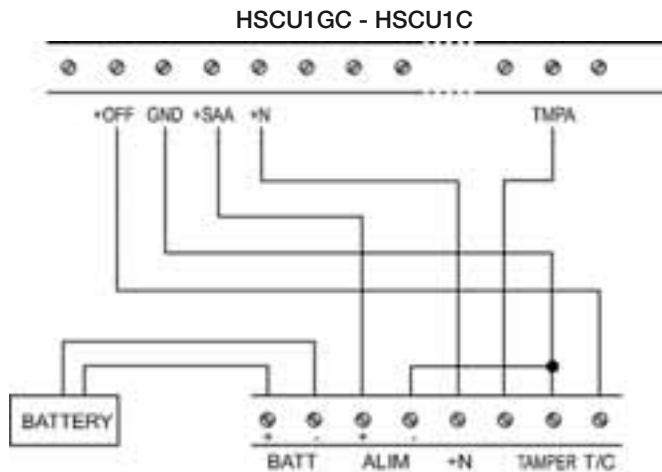

For electrical connections, proceed in the following sequence:

- connect the battery: the lamp starts flashing (it remains lit if the battery connection is inverted).
- connect the power supply to the control panel: P.SUPPLY + and -
- connect the +N activation signal: the lamp starts flashing immediately and 2 acoustic signals are emitted for approx. 2 seconds to confirm the siren standby status.
- connect the tamper output
- if present, connect the T/C alarm block command

### 4.15.6 - OPERATION

HSSOC signals intrusion with a powerful acoustic alarm. On each alarm trip from the control panel (+N), it emits an alarm signal lasting approx. 3 minutes; the alarm signal terminates when the control panel is deactivated.

If the "alarm block" connection is envisaged (T/C connected to +OFF of control panel) when the control panel is off, the siren is "blocked"; i.e. even if the alarm is activated (+N), no acoustic signal is activated, which normally occurs when the control panel is ON. Also, for each control panel arming phase, the acoustic signals occur each time the alarm (+N) is armed, only until the programmed count is reached; the siren is then blocked when this number is exceeded.

The cycle count is reset when the control panel is switched off.

### Luminous signals:

- 4 flashes = confirms arming of the control panel
- 1 flash = confirms disarming of the control panel



## 4.16 - Indoor siren (model HSSI)

### 4.16.1 - SPECIAL WARNINGS

Install the product in a location difficult to reach, to avoid inadvertent damage, possibly in a location where the sound produced can be propagated to the various other rooms.. If necessary, fit additional sirens.

### 4.16.2 - PRODUCT DESCRIPTION AND INTENDED USE

HSSI is a siren via radio with sound power of 114 dB; designed to signal intrusion and also to dissuade intruders. The unit is battery powered, can be wall-mounted and thanks to the compact dimensions can be positioned in concealed areas. Designed for indoor use.

Any other use is to be considered improper and is strictly prohibited! Nice declines all liability for damage resulting from improper use of the product and other than as specified in this manual.

### 4.16.3 - OPERATION

HSSI signals intrusion with a powerful acoustic alarm. On each alarm command send by the control panel, it emits an alarm signal lasting approx. 3 minutes; the alarm signal terminates when the control panel is disarmed.

If the siren housing is opened (without first setting the associated control panel to TEST mode) an alarm signal is activated for approx. 3 minutes.

### Acoustic signals:

- 4 beeps = confirms activation of the control panel
- 1 beep = confirms deactivation of the control panel
- series of beeps for approx. 20 seconds on activation or deactivation of the control panel = batteries discharged

On activation of the battery discharged signal, the batteries must be replaced as soon as possible. Incorrect alarm signals may be generated when batteries are discharged.

### 4.16.4 - INSTALLATION

For installation procedures, refer to the relative instruction manual.

**Volume adjustment:** turn the potentiometer (fig. 29) to modify the volume of the beeps.

### 4.16.5 - PROGRAMMING

HSSI performs a self-programming function when activated/deactivated for the first time on the control panel; 6 beeps are emitted to confirm programming.

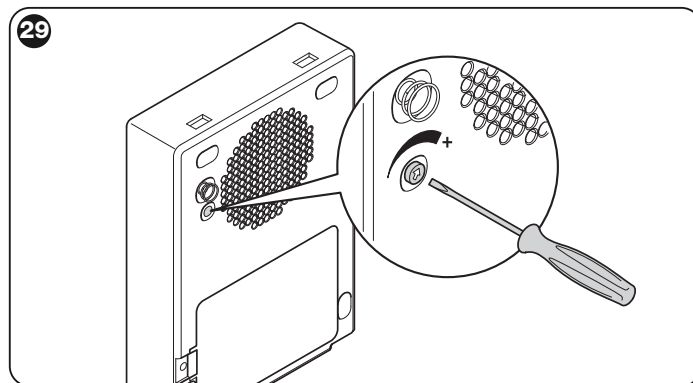

## 5 ELECTRICAL CONNECTIONS

### 5.1 - Warnings

- The connection to the mains must be performed by skilled and qualified personnel in observance of standards governing electrical installations.
- On the system, fit a 2-pole disconnect device with a gap between contacts of at least 3 mm, or use an electric cable equipped with a plug suited to a standard socket.
- Run any tests with battery power only (the battery must be fully charged).

### 5.2 - Connections on the control panel (models HSCU1GC and HSCU1C only)

**Caution!** – Before opening the control panel housing, always disconnect the mains power supply.

**01.** To connect the mains power cable, insert the ferrite cylinder as shown in fig. 31 and position as shown in fig. 32;

**Warnings:**

- To facilitate insertion of the wires on the terminals, press the relative release button.
- The wires must be secured by tightening the screw on the terminal cover;

**02.** To make electrical connections to the terminal board, refer to Table 4;

**03.** To insert the backup battery (not supplied) refer to fig. 33;

**04.** On completion of connections, close the internal cover and only then activate the disconnect device and insert the plug in the socket.

### 5.3 - Connections on siren model HSSOC

To make the electrical connection between the siren and control panel, refer to Table 4 and see fig. 36

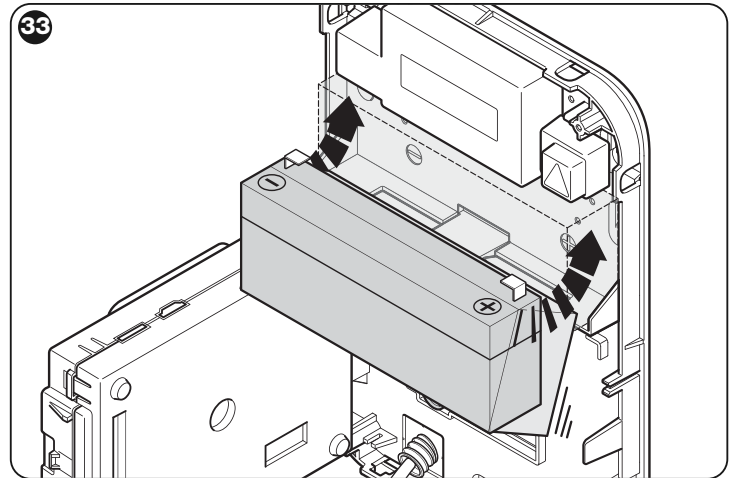
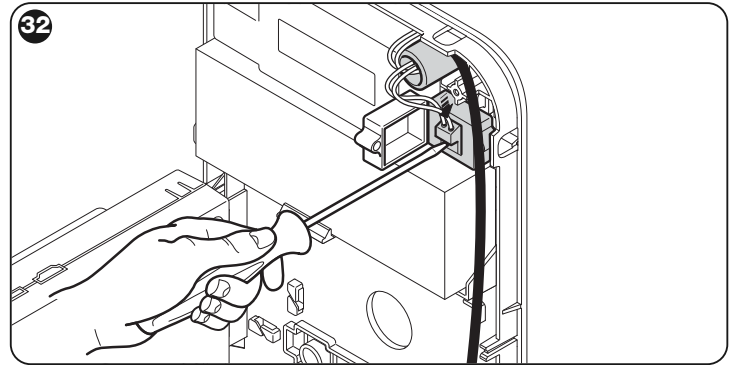
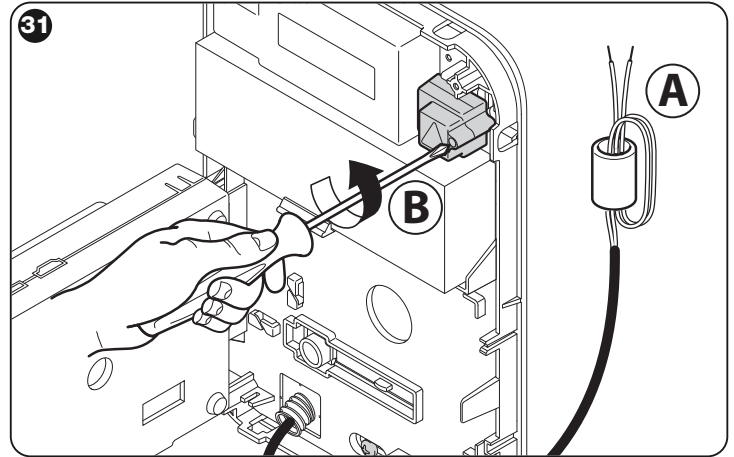

**TABLE 4 - DESCRIPTION OF ELECTRICAL CONNECTIONS**

| OUTPUT         | DESCRIPTION  |
|----------------|--|
| SPK            | External loudspeaker output (8 Ω). Suitable for additional loudspeaker that reproduces the control panel messages; see fig. 34   |
| + ALI          | Positive always present, for power supply of wired detectors; 12 Vdc maximum 500 mA; see fig. 35   |
| + OFF          | Positive present when control panel is activated, for wired siren block command ; see fig. 36  |
| GND (all)      | Negative for all connections   |
| + SIR          | Positive in alarm status, for additional sirens; 12 Vdc maximum 500 mA; see fig. 37  |
| + SAA          | Positive (14 Vdc) for battery charger of wired sirens (not present in event of mains power failure; see fig. 36  |
| + N            | Positive on absence , for alarm command on wired sirens. If more than one siren is connected, a diode must be inserted to avoid the return signal; see fig. 36. <b>Caution!</b> – Do not use this output to power the sirens |
| KEY            | Input for external key (closed = control panel disarmed); see fig. 38  |
| A1-2 B1-2 C1-2 | NC alarm inputs; see fig. 39   |
| TMP A-B-C      | NC auto-protect (tamper) inputs; see fig. 39   |
| NC1-COM1-NO1   | R1 relay output (connect only to SELV extra low voltage safety circuits); see fig. 40  |
| NC2-COM2-NO2   | R2 relay output (connect only to SELV extra low voltage safety circuits); see fig. 40  |
| PHONE          | Connection to fixed PSTN telephone line; see fig. 6  |
| PC             | Connector for connection to PC (requires specific USB interface); see fig. 6   |

**Notes:**

- The alarm and tamper inputs must be NC and are enabled on initial closure. If closed inadvertently they indicate an alarm status. To clear the signal, enter and exit CONTROL PANEL TEST mode;
- The TMP inputs must be programmed on the same groups as the corresponding detectors.



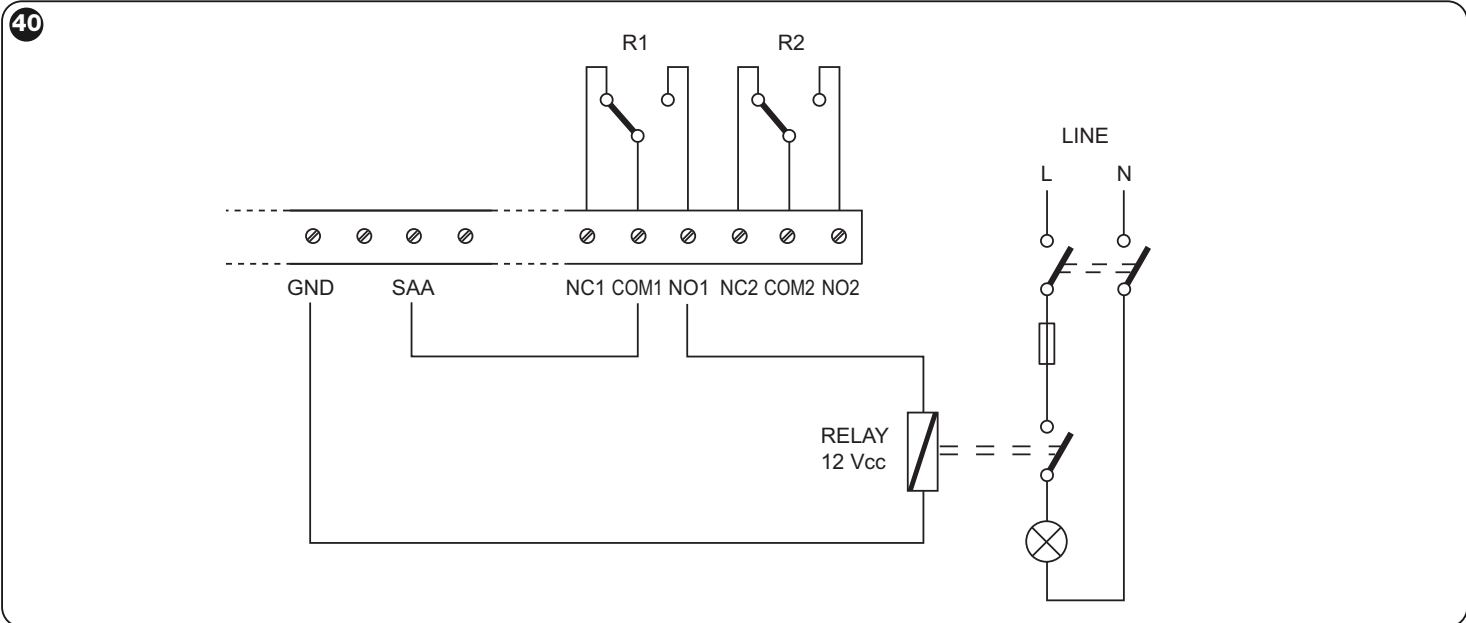
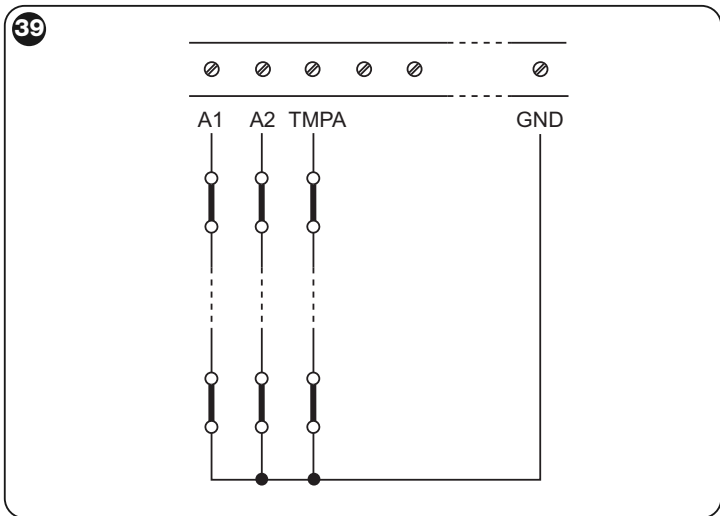
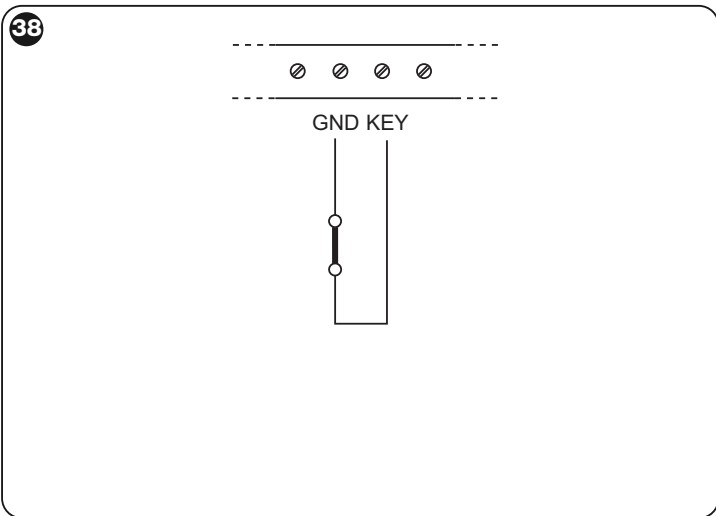
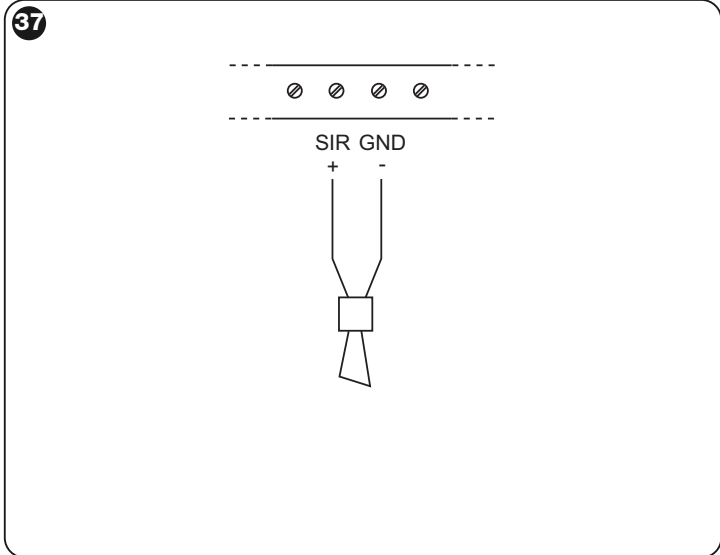
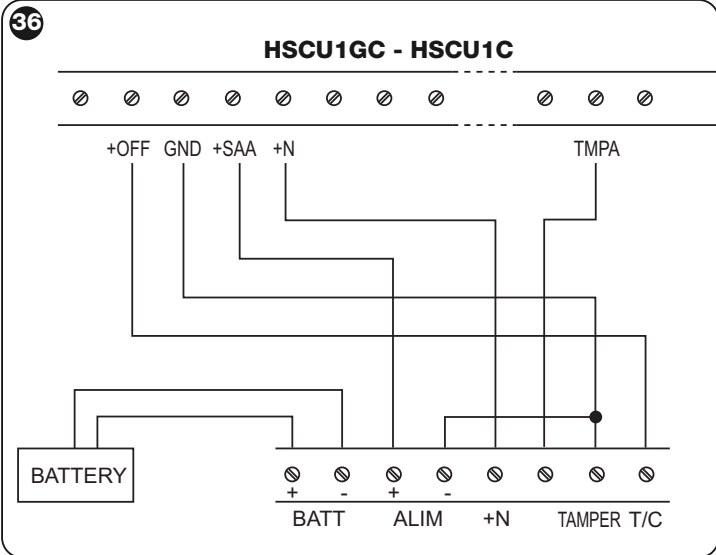
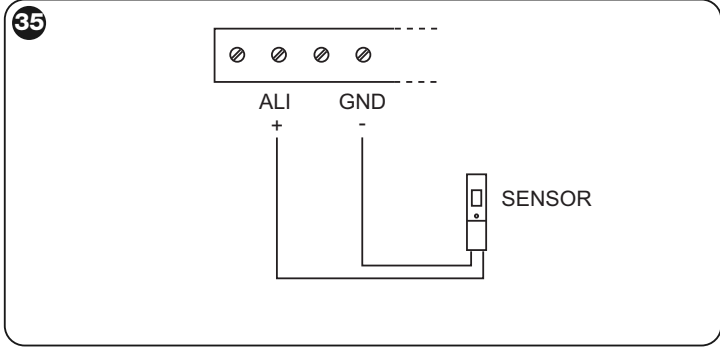
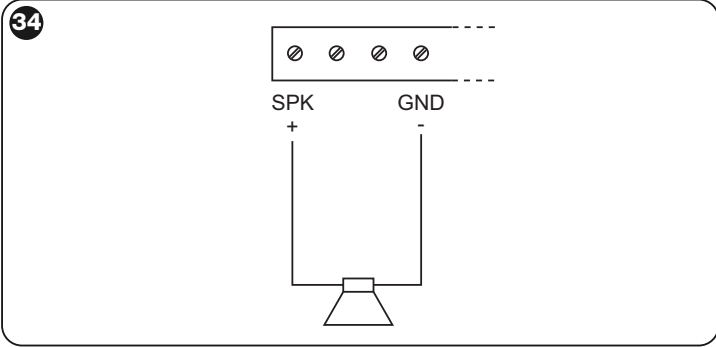

# 6 CONTROL PANEL PROGRAMMING

The control panel is programmed via the keypad on the control panel, according to the instructions on screen and the vocal guide provided in the main phases of programming.

General rules for programming:

- Modifications to settings must be confirmed by pressing the key **OK**; if not confirmed, the modification is not saved.
- When the display shows the symbols  $\updownarrow$  this means that the user can scroll up through the list using key **▲**, or down through the list using key **▼**.
- When the display shows the symbol **OK** this means that the user must confirm the operation by pressing **OK**.
- When the display shows the letters **Y** or **N** this means that the function is active (Y = Yes) or not active (N = No) to modify the parameter, use the arrow keys **▲** and **▼**.
- To exit a function, press **ESC**.
- To cancel a setting, press **C**.
- To cancel part of a setting during entry, press **◀**.
- To enter the hour, date, minutes and seconds, and wherever a numerical entry is required, use the **numerical keys**.
- To associate telephone numbers with vocal and SMS messages, use the **numerical keys**.
- To select zones A, B and C use keys **1**, **2** and **3** respectively and in some cases 4,5 and 6.

In the event of errors during entries there are no serious consequences; the appliance simply indicates the error with one or more beeps.

**Take special care when using the function "DELETE" (followed by the request "DELETE - CONFIRM?") which if confirmed will delete all settings!**

## 6.1 - Initial start-up and configurations

When the battery is connected, the display lights up and the control panel firmware version code is shown on screen.

Press any key to display the function to select the language used in the control panel menus. Scroll through the languages using keys **▲** and **▼** and press **OK** to confirm.

From here on, vocal instructions are given; the messages are stored in the system memory (located next to the GSM SIM card) and are in one language only, corresponding to the language of the manual supplied with the control panel. Memories with other languages are available on request.

### 6.1.1 - Safety codes: "factory code", "user code" and "installer code"

The control panel has a factory code: "0000" to enable initial access to the programming procedure. The two different codes must then be programmed as follows:

- **user code:** (from 4 to 8 digits) enables activation of the manoeuvres and access to a number of settings;
- **installer code:** (from 4 to 8 digits) enables access to all settings but not to manoeuvres.

**Caution!** - Do not forget these codes or the control panel will need to be opened (generating a "tamper" alarm), disconnect the power supply and re-connect, then initialise the system after entry of the factory code (this operation does not delete the settings made).

After entering the factory code the system requests entry of the current time and date for the internal clock. The internal clock is used in the event log and the timed programmer.

After also entering the user code and installer code, the first item of the programming menu is displayed. To display the other menu items, use keys **▲** and **▼**.

## 6.2 - Programming menus (see Menu 1)

| MENU 1               |  |
|----------------------|--|
| PHONE BOOK           | Enables the memorisation, display and modification of telephone numbers for alarm calls.   |
| MESSAGES             | Enables recording of alarm messages and emergency assistance requests. In total, the system can store 6 voice messages and 6 SMS text messages. There are also 11 pre-set technical SMS text messages. |
| EXTRAS               | Enables configuration of system devices (Codes, Remote controls, Detectors, etc).  |
| SETTINGS             | Enables programming of special control panel functions (Exit time, automatic activation etc.)  |
| DIGITAL PROTOCOLS    | Enables configuration of digital communication protocols with alarm receiving centres.   |
| PC REMOTE MANAGEMENT | Enables configuration of the remote technical assistance options.  |

### 6.2.1 - PHONE BOOK → MEMORY

This section enables memorisation of the names and telephone numbers of persons who will receive alarm messages and technical system information. The phone book can store up to 63 names (items). Position number 64 can be

programmed exclusively with the number provided by the SIM card operator to display residual credit. Therefore, when the control panel is active, credit can be displayed automatically by pressing  $\text{☎}$ .

For each item of the phone book, compile all fields (see **Menu 2**).

| MENU 2            |                  |   |   |
|-------------------|------------------|---|---|
| NAME              |                  | (maximum 13 characters) name of the person or authority corresponding to the telephone number.                                    |   |
| NUMBER            |                  | (maximum 16 digits) telephone number to be dialled by PSTN or GSM telephone diallers.   |   |
| MESSAGE           |                  | selects one or more vocal messages (see 6.2.2) to be sent to the specific telephone number when the event occurs.                 |   |
| SMS               |                  | selects one or more SMS messages (see 6.2.3) to be sent to the specific telephone number when the event occurs.                   |   |
| TECHNICAL SMS     |                  | selects one or more technical SMS messages to be sent to the specific telephone number when the event occurs.                     |   |
| <b>HSCU1GC N°</b> | <b>HSCU1G N°</b> | <b>Event that causes delivery of text message</b>   | <b>Pre-configured TECHNICAL text messages (not modifiable)</b>        |
| 1                 | 1                | control panel battery discharged  | LOW BATTERY CONTROL PANEL   |
| 2                 | 2                | detector battery discharged   | LOW BATTERY PERIPHERAL  |
| 3                 | 3                | supervision failure and/or radio disturbance present (check event log)  | SUPERVISION FAILURE OR SCANNER  |
| 4                 | 4                | system armed (message only sent in response to arming via telephone)  | CONTROL PANEL ARMED   |
| 5                 | 5                | system disarmed (message only sent in response to activation via telephone)   | CONTROL PANEL DISARMED  |
| 6                 | -                | electrical mains failure message sent after a mains power failure lasting for the set time interval (see SETTINGS)                | MAINS FAILURE<br>On return of mains power: CONTROL PANEL MAINS RETURN |
| 7                 | -                | no GSM network coverage for more than 15 minutes (the message is sent on return of the GSM signal)                                | NO GSM NETWORK  |
| 8                 | 6                | no successful call on PSTN line (check for any interruptions on the fixed telephone line)   | NO SUCCESSFUL CALL ON PSTN LINE                                       |
| 9                 | 7                | periodic message to indicate that the system is running (message sent after a certain number of programmable hours; see SETTINGS) | PERIODICAL CALL OK  |

|                      |   |  |              |
|----------------------|---|--|--------------|
| 10                   | 8 | SIM expiry warning message (programmed expiry, see SET-TINGS)  | SIM VALIDITY |
| <b>DIRECT ACCESS</b> |   | Enables (yes) or disables (no) the option for direct access from this number; i.e. the possibility of calling the control panel from a mobile phone and enable operations without entry of the user code as the caller ID is recognised automatically by the system. |              |

### Notes for recording numbers in the phone book.

- **Telephone line check:** the control panel normally listens for the free PSTN line tone before making the call. If the line is disturbed, the control panel may not detect a free line. Therefore, to cancel this check process, enter the symbol \* (press ▲) in the programming phase as the first digit of the telephone number.
- **Pause between numbers:** if a pause occurs between one number and the next when dialling numbers, enter the symbol P (press ▼) at the point of the pause.

## 6.2.2 - MESSAGES → VOCAL MESSAGES

This section enables the recording of voice alarm messages to be sent to the respective numbers in the phone book (those associated with the message during the programming phase) Up to 6 messages can be recorded... 6 messages are available (plus message N° 7) for a total recording of max. 240 seconds.

### Recording voice messages

To record the various voice messages associated with alarm events, proceed as described below, with reference to **Menu 3** and the following warnings:

- **For messages N° 1 to N° 6.**  
Each of these messages proposes a specific event as set in the factory (see **Menu 3**). If the association is as required on your system, during the procedure simply press **OK** to confirm; otherwise refer to the paragraph "Replacing the voice event association".
- **For voice message N°1 – ALARM ZONES A, B, C.**  
The message is normally sent in the event of an alarm in any of the system group zones (A, B, C). However, during the procedure, some of these zones can be excluded so that the message is not transmitted (for example in the case of an external alarm).  
To exclude a zone, press the number corresponding to the zone: 1 = zone A, 2 = zone B, 3 = zone C. Then confirm selection by pressing **OK**. The display then shows the enabled zones. **Note** – The enable function applies only to the telephone transmission of the alarm message.
- **For voice message N° 7.**  
This message, which must be recorded directly by the user, is a reminder which is read by the control panel to the user when the latter calls the unit.

Some examples of recorded phrases:

- to check the control panel status, press: **0, #**
- to disarm the control panel press: **0, \*, 0, #**
- for total arming of the control panel, press: **0, \*, 1, #**
- to activate system zones A and B press: **0, \*, 2, #**

in the case of using home automation actuators controlled telephonically (light activation, electrical appliance control etc.) we recommend completing guide message N°7 with all information in Table A (paragraph 9.2.9).

Vocal message recording procedure:

01. From the menu MESSAGES press **OK** to confirm: VOCAL MESSAGES is displayed.
02. Press **OK** again to confirm: VOCAL MESSAGE N°1 is displayed.
03. Select the required message using keys ▲ and ▼ and press **OK** to confirm. The text **OK TO RECORD** is displayed.
04. Press and hold **OK** and start to record the message. During recording, the remaining recording time is displayed.
05. At the end of recording, release **OK**. The control panel automatically replays the message.
06. If required, listen to the message again by pressing **OK**.
07. If recording is successful, press **ESC** to confirm the recorded message and exit the procedure.
08. If the recording is not satisfactory, press **C** to cancel and repeat the procedure.

This procedure can be used to record, re-listen to and modify the various messages.

| <b>MENU 3</b> |  |
|---------------|--|
| Message       | EXAMPLES of alarms to be recorded and relative events  |
| N° 1          | <b>ALARM GROUP A,B,C:</b> this regards all indoor and outdoor intruder detectors – example of message: "Warning: robbery alarm at home of Rossi, via Pascoli 10 Rome"; (the specific detector that tripped the alarm is then specified).                             |
| N° 2          | <b>TAMPERING ALARM:</b> all tamper-proof devices can trip this alarm – example of message: "Warning: tamper alarm at home of Rossi, via Pascoli 10 Rome"; (the specific detector that tripped the alarm is then specified).  |
| N° 3          | <b>PANIC ALARM:</b> alarm activated manually by the user via transmitter or keypad – example of message: "Warning: danger at home of Rossi, via Pascoli 10 Rome"; (the name of the person who activated the alarm is then specified).                                |
| N° 4          | <b>ROBBERY ALARM (or distress):</b> alarm activated manually by the user via transmitter or keypad – example of message: "Warning: request for first aid at home of Rossi, via Pascoli 10 Rome"; (the name of the person who activated the alarm is then specified). |
| N° 5          | <b>TECHNOLOGICAL ALARM:</b> alarm activated by technical sensors (smoke, flooding, and others) – example of message: "Warning: flooding alarm signal at home of Rossi, via Pascoli 10 Rome"; (the specific detector that tripped the alarm is then specified).       |
| N° 6          | <b>LOW BATTERY ALARM</b> signal to indicate low battery charge on one of the system devices – example of message: "Warning: low battery on system of Rossi, via Pascoli 10 Rome"; the device with the low battery is then specified.                                 |

### Replacing the vocal event association

For each of the 6 voice and text messages, the factory-set associated event may be modified as required. During the configuration phase, select a different event using the keys (▲ ▼); for special events, see **Menu 4**.

| <b>MENU 4</b>  |                |
|--|----------------|
| <b>Special EVENTS</b>  |                |
| <b>MAINS FAILURE</b> (models HSCU1GC and HSCU1C only): the call is made after a programmable interval (see SETTINGS) of mains failure to the control panel from the electrical mains – example of message "Warning: power failure at home of Rossi, via Pascoli 10 Rome" |                |
| <b>PERIODIC CALL:</b> the call is made after a programmable number of hours (see SETTINGS) to confirm correct operation of the control panel – example of message "Alarm system operation OK at home of Rossi, via Pascoli 10 Rome"                                      |                |
| <b>TEMPERATURE:</b> the call is made when the control panel temperature exceeds 70°C or falls below 5°C – example of message: "Warning: abnormal temperature at home of Rossi, via Pascoli 10 Rome"  |                |
| <b>Special event alarm</b> ( display ____ / ____ ). A special alarm can be programmed to generate a call when a special event occurs.<br>Possible events are:  |                |
| ALL  | allarm         |
| OPEN   | door left open |

|                  |                            |
|------------------|----------------------------|
| BATT             | battery low                |
| DISARM.          | disarming                  |
| IN A (or B or C) | arming of specific group   |
| ARM              | activation                 |
| SUPERV           | supervision alarm          |
| SCAN             | scanner alarm              |
| END AL           | door reclosed              |
| MAN              | tamper alarm               |
| TEMPERATURE      | hot/cold temperature alarm |

To program an alarm, the **event** must be written in the first section of the display (example: to write "low battery" enter BATT and press **OK** to confirm); then in the second section, write the **nome** assigned to the device that generates the event (see EXTRAS); for control panel write CONTROL PANEL and press **OK** to confirm.

**NO EVENT**: no call is made on confirmation of this event (used for example to temporarily disable an alarm)

### 6.2.3 - MESSAGES → SMS MESSAGES

This section enables writing of SMS messages to be sent to the respective numbers in the phone book (those associated with the message during the programming phase) a maximum of 6 messages are available.

#### Programming SMS messages

To personalise the 6 SMS text messages, proceed as follows:

01. From the menu MESSAGES press **OK** to confirm: the text VOCAL MESSAGES is displayed.
02. Press **▼**: SMS MESSAGES is displayed; press **OK** to confirm.
03. Press **OK** again to display SMS MESSAGE N°1.

From here onwards the operations are the same as those for the vocal messages with the difference that SMS messages are text only and must be written using the alphanumerical keypad, in the same way as on a normal mobile phone. The maximum text length is 24 characters.

### 6.2.4 - EXTRAS

This menu enables the configuration of system devices on the control panel.

#### 6.2.4.1 - EXTRAS → REMOTE CONTROLS

The remote control menu enables configuration of hand-held transmitters used to arm and disarm the control panel.

Each remote control can be programmed to arm or disarm all or only some of the groups A, B and C. To program a transmitter, proceed as follows:

01. From the menu EXTRAS press **OK** to confirm: REMOTE CONTROLS is displayed
02. Press **OK** again to confirm: REMOTE CONTROL 1 is displayed (or the first free space).
03. Press **OK** again to access the groups activated or deactivated by this remote control.
04. Use keys 1, 2, and 3 to set groups A, B, C to ON, and keys 4, 5, 6 to set to OFF.
05. Press **OK** again to confirm:

The specific parameters of the remote control must then be entered, starting with memorisation in self-learning mode.

06. Press the keys **OFF** and **ON** simultaneously; a confirmation beep is emitted (if the remote control is already memorised, 3 Beeps indicate an error).
07. Press **OK** again to confirm memorisation,
08. Use the alphanumerical keypad to write a text that enables recognition of the transmitter (normally the owner's name – maximum 9 characters). On completion, press **OK** to confirm.
09. Record the vocal message for transmitter recognition; press and hold **OK** during recording.
10. If recording is successful, press **ESC** to confirm the recorded message and exit the procedure.

Repeat the same procedure for all remote controls to be programmed on the system (maximum 32 remote controls).

11. To delete a programmed remote control, select it, press **C** and then press **OK** to confirm deletion.

#### 6.2.4.2 - EXTRAS → CODES

The codes menu enables configuration of the numerical codes (5 digits) used to arm and disarm the control panel, via the keypad on the control panel or other keypads as required. Each user should have a personal code. This enables tracking of the precise identity of who performed the operation recorded in the event log. To configure the codes, proceed as follows:

01. From the menu EXTRAS press **OK** to confirm: REMOTE CONTROLS is displayed
02. Press **▼**: CODES is displayed; press **OK** again to confirm: CODE 1 is displayed (or the first free space).

From here onwards, the operations are the same as those for the remote controls, with the difference that the codes must be entered on the keypad.

#### Note for ANTIDURESS function

This function enables deactivation of the alarm, for example when under threat, by entering a different code from the normal version, but which activates the robbery alarm at the same time (**Caution**: the specific robbery message must be configured and associated with the numbers in the phone book).

01. When the control panel displays the option UNDER THREAT, if the user wants the previously entered code to be used as the Under Threat code, activate the function by pressing **▲** (the symbol N on the screen becomes Y) and press **OK** to confirm; otherwise to leave the function disabled, press **OK**.

Repeat the same procedure for all codes to be programmed using this function (maximum 32 codes).

02. To delete a programmed code, select it, press **C** and then press **OK** to confirm deletion.

#### 6.2.4.3 - EXTRAS → ALARM GROUP A (or B or C)

In the alarm menu, detectors can be memorised one by one, as planned and associated with a specific group. Therefore first select the required group (the procedure below uses group A as an example) and memorise the detectors as follows:

01. From the menu EXTRAS press **OK** to confirm: REMOTE CONTROLS is displayed
02. Press **▼** twice : ALARM GROUP A is displayed; press **OK** to confirm.
03. The second line displays EXT AL N
04. If the user wants an alarm in zone A to trip an outdoor alarm (voice alarm only), activate the function by pressing **▲** (the symbol N on the screen becomes Y) and press **OK** to confirm; otherwise to leave the function disabled (i.e. only siren sound), press **OK**. **Caution! - If the outdoor alarm function is activated, the voice message MSG2 must be memorised on the siren!!!** (see paragraph 4.15).
05. SENSOR A01 is displayed (or the first available number); use keys **▲ ▼** to select the planned number of the sensor to be memorised and press **OK** to confirm.
06. The second line displays DELAY IN N AND N: this factory setting (symbol N on display) indicates that there is no delay (the sensor trips the alarm immediately) and there are no 2 sensors envisaged with AND in between. At this point the first or second function can be activated as required (or also both) using respectively keys 1 or 2 (the symbol N on display changes to Y). Press **OK** to confirm:
07. If the input delay function has been enabled, the system request entry of the delay time (from 0 to 99 seconds). Use the numerical keypad to enter the required time and press **OK** to confirm.
08. The second line displays INSERT BATTERY: this indicates that the battery must be inserted in the detector.
09. After inserting the battery, the detector performs a number of transmissions and the control panel emits a beep to indicate that the detector has been memorised correctly. If the function AND was previously enabled, the bat-

tery must now be inserted as well as the second sensor for relative memorisation. Press **OK** to confirm.

10. LABEL A01 is then displayed; use the alphanumeric keypad to write a text to enable detector recognition (maximum 9 characters). On completion, press **OK** to confirm.
11. Record the vocal message for detector recognition; press and hold **OK** during recording.
12. If recording is successful, press **ESC** to confirm the recorded message and exit the procedure.

Repeat the same procedure for all detectors planned for group A.

#### Note on memorisation of detectors

Once a detector is memorised and associated with a specific group, it can no longer be memorised in other groups.

If an association is to be subsequently changed, a detector can be deleted and then memorised in a different group.

- To delete a detector, select it, press **C** and then press **OK** to confirm deletion.

As well as the alarm group A, groups B and C are also available. To memorise the detectors planned and associated with these groups, perform the same operations as per group A.

#### 6.2.4.4 - EXTRAS → 24H PANIC AL. (or 24H ROBBERY, or 24H TECNOL.)

As well as the 3 alarm groups A, B and C (which can be activated or deactivated as required), other constantly active groups are also available as follows:

- **PANIC**: group used to program keys of remote controls or keypads for manual alarm activation.

- **ROBBERY**: group used to program keys of remote controls or keypads for manual telephone alarm calls or requests for first aid.

- **TECHNOLOGICAL**: group used to program technical alarm detectors (smoke, flooding, gas, etc.)

#### 6.2.4.5 - EXTRAS → 24H PANIC; EXTRAS → 24 ROBBERY

To program the keys of the remote controls or keypads in the groups PANIC and ROBBERY, after selecting EXTRAS → 24H PANIC ( or 24H ROBBERY) the same procedure is performed as per memorisation of the remote controls, with the difference that the key must be held for at least 10 seconds to complete memorisation.

#### 6.2.4.6 - EXTRAS → 24H TECHNOL

To program the detectors in the TECHNOLOGICAL group, select EXTRAS → 24H TECHNOLOGICAL, and perform the same procedure as described for programming group A.

In all the control panel can memorise up to 99 detectors in the various groups (2 detectors in AND mode are considered as 1); this calculation also includes the bidirectional sirens and remote control keys with panic and robber functions or .

#### 6.2.4.7 - EXTRAS → WIRED INPUTS

The control panels HSCU1GC and HSCU1C are fitted with a terminal board with 6 inputs for the same number of lines to which detectors can be connected (with NC contact output); they also have 3 tamper inputs (NC contact). For details of connections, see chapter 5.

The presence of these inputs is recognised by the control panel in self-learning mode. If the inputs are then to be cancelled, simply set the control panel Test function and eliminate connections.

These inputs are factory set with the following standard associations (the association can be changed at any time as required):

| Input | Association                            |
|-------|--|
| A1    | 1 <sup>st</sup> input of alarm group A |
| A2    | 2 <sup>nd</sup> input of alarm group A |
| TMPA  | Tamper of group A                      |
| B1    | 1 <sup>st</sup> input of alarm group B |
| B2    | 2 <sup>nd</sup> input of alarm group B |
| TMPB  | Tamper group B                         |
| C1    | 1 <sup>st</sup> input of alarm group C |
| C2    | 2 <sup>nd</sup> input of alarm group C |
| TMPC  | Tamper group C                         |

As in the case of detectors connected via radio, the following can also be programmed for each of those wired to the inputs:

- The associated alarm group (A, B or C)
- The input delay time
- Text label
- A vocal recognition message

Each tamper input can be associated with:

- The associated alarm group (A, B or C)

For these settings, perform the same procedure as described for programming group A.

#### 6.2.4.8 - EXTRAS → EXTERNAL KEY

The control panels HSCU1GC and HSCU1C are fitted with a KEY input on which a contact can be connected for control panel arming or disarming; arming can be total or partial according to the setting.

The contact must be: **closed**, for control panel disarmed and **open**, for control panel armed.

The control panel switches its status according to changes in the status of the contact, but it can be subsequently controlled by other devices, such as remote controls with which the control panel can be disarmed even when the KEY contact is open.

To program this input, perform the same procedure as described for transmitter memorisation.

### 6.2.5 - SETTINGS

This menu enables configuration of a number of control panel functions.

#### 6.2.5.1 - SETTINGS → EXCL. SENSORS

One or more sensors can be deactivated (for example in the event of a malfunction). To deactivate a sensor, proceed as follows (the user code can also be used to access the menu):

01. From the menu SETTINGS press **OK** to confirm: EXCL. SENSORS is displayed
02. Select the required sensor using keys **▲** and **▼** and press **OK** to confirm.
03. INCLUD is displayed on the second line; if the sensor is operative, or EXCLUD if the sensor is disabled.
04. To change the status use keys **▲** and **▼** and press **OK** to confirm.

**Note** - Deactivation does not delete the sensor but simply enables the system to ignore any alarms sent by the sensor (these alarms are not recorded in the event log).

#### 6.2.5.2 - SETTINGS → EXCL. WIRED INP.

For wired inputs on the control panels HSCU1GC and HSCU1C, refer to the previous paragraph (SETTINGS → EXCL. SENSORS).

#### 6.2.5.3 - SETTINGS → RELAY1 SETTINGS (or RELAY2)

The control panels HSCU1GC and HSCU1C are equipped with 2 relay outputs. Output RELAY 1 is factory set for the ON-OFF function

Output RELAY 2 is factory set for the GENERAL ALARM function. These settings can be modified with one of the functions specified in **Menu 5**. To modify, first select the relative relay (the procedure below uses relay 1 as an example) and proceed as follows:

01. From the menu SETTINGS press **OK** to confirm: EXCL. SENSORS is displayed
02. Press **▼** twice (or 3 times if programming relay 2): RELAY1 SETTINGS is displayed; press **OK** to confirm:
03. (ON-OFF appears on screen) Use keys **▲ ▼**, to select the required function. **Note** – In the case of the function PULSE, the second line displays the time; therefore use the numerical keys to enter the required value.
04. On completion, press **OK** to confirm.

### MENU 5

ON – OFF

PULSE

Toggle function, switching to ON or OFF according to the setting of an internal clock (see 9.2.7); or from a command via telephone

Switches to ON for a time settable from 0 to 999 seconds according to the setting of an internal timer program (TIME ON); or from a command via telephone

|                              |   |
|------------------------------|---|
| <b>GENERAL ALARM</b>         | Switches to ON for 3 minutes in the case of a general alarm (excluding antiscanner)   |
| <b>TAMPER</b>                | Switches to ON for 3 minutes in the case of a tamper alarm  |
| <b>PANIC</b>                 | Switches to ON for 15 seconds in the case of a panic alarm  |
| <b>ROBBERY</b>               | Switches to ON for 15 seconds in the case of a robbery alarm  |
| <b>TECHNOLOGICAL ANOMALY</b> | Switches to ON for 15 seconds in the case of a technological alarm  |
| <b>ARM./DISARM</b>           | Switches to ON for 15 seconds in the case of low batteries (of control panel or detectors), supervision failure, radio disturbance with system activated (antiscanner), GSM network failure |
| <b>INP. DELAY</b>            | Switches to ON on activation and OFF on deactivation (useful for connecting an "alarm active" indicator light)  |
|                              | Switches to ON during the input delay set on one or more detectors  |

### 6.2.5.4 - SETTINGS → RADIO OUTPUTS

The control panels are equipped with 16 radio outputs. These are sent via radio to receivers set up for the control of motors for rolling shutters, lighting control or electrical appliances (for example, HSTT2N and HSTT2L).

These commands can be activated exclusively via telephone calls to the control panel; however these receivers can also be controlled directly with transmitters or keypads, by memorising the control keys accordingly.

In terms of the receivers, the control panel acts as a radio control transmitter; therefore these controls must be memorised in self-learning mode on the receiver.

There are two types of command: PULSE (each command switches the receiver output for the time as set on the receiver) or ON-OFF (i.e. one command for ON and one for OFF). To configure these radio commands, proceed as follows:

**01.** From the menu SETTINGS press **OK** to confirm: EXCL. SENSORS is displayed.

**02.** Press **▼** four times : RADIO INPUTS is displayed; press **OK** again to confirm.

**03.** RADIO 1 appears on screen; use keys **▲ ▼**, to select the required command number.

**04.** The second line displays PULSE (this can change from ON-OFF using keys **▲ ▼**).

**05.** Before confirming, set up the receiver to receive the code for the self-learning function (see the specific receiver instructions).

**06.** Press **OK** to program the receiver (this confirms the operation).

Repeat the same procedure to program all required commands and relative receivers.

### 6.2.5.5 - SETTINGS → ...

The settings menu also enables the configuration of a number of special parameters and functions, used to optimise operation of the control panel in specific **Menu 6**.

|                           |   |
|---------------------------|---|
| <b>MENU 6</b>             |   |
| <b>GSM/TELEPHONE LINE</b> | Enable selection of priority between GSM and the PSTN line for emergency calls.   |
| <b>MAINS FAILURE</b>      | Enables the delivery of SMS messages in the event of a mains power failure and programming of a standby time in minutes prior to delivery.  |
| <b>PERIODIC CALL</b>      | Enables the delivery of periodic SMS messages and programming of the frequency of delivery in hours.  |
| <b>SIM VALIDITY</b>       | Enables the delivery of SMS messages warning of SIM validity expiry and programming of the remaining validity in months.  |
| <b>TIME AND DATE</b>      | Enables update of the system time and date; these data are used to program timed functions and the event log.   |
| <b>TEL. EXCHANGE</b>      | Enables entry and specification on the control panel of a number for access to the PSTN network, if an alarm receiving centre is present. For increased safety, it is preferable not to connect the control panel to a switchboard but connected directly to the line.  |
| <b>INSTALLER CODE</b>     | Enables checks and changes to the installer access code.  |
| <b>ANTISCANNER</b>        | Enables activation of the function ANTISCANNER and the definition of the time interval of disturbance to be considered negligible (from 1 to 60 seconds) The control panel checks the radio disturbance signals in the environment; when the set time interval elapses, the control panel siren alarm is activated (for 30 seconds) as well as the SIR terminal output. |
| <b>SUPERVISION</b>        | Enables the SUPERVISION function, i.e. a system check that all devices are running, transmitted approximately every 40 minutes. Absence of the signal for over 3 hours by a device generates the specific signal and each time the system is switched on or off.  |
| <b>EXIT TIME</b>          | Enables entry of the time between activation and effective operation of the alarm system. This is factory set at 60 seconds. The user is recommended to avoid excessively short intervals to avoid rushed exits.  |
| <b>AUTO SUMMER H</b>      | Enables deactivation of automatic control of daylight saving time.  |
| <b>BACKLIGHTING</b>       | Enables selection of permanent display lighting. This function significantly reduces autonomy of the control panel in the event of a power failure.   |
| <b>VOLUME</b>             | Enables adjustment of the volume of the control panel vocal guide. If the volume is set to zero, the vocal Activation/Deactivation notification messages are also disabled.   |
| <b>FORCED ARMING</b>      | Enables the function for arming the control panel (totally or partially) at a precise time. Disarming is manual only.   |
| <b>FW VERSION</b>         | Displays the control panel firmware version.  |
| <b>SYSTEM RESET</b>       | Enables total deletion of all control panel parameters, including the event log. <b>Caution:</b> this operation is not reversible.  |

### 6.2.6 - DIGITAL PROTOCOLS

(advanced setting, without vocal guide)

This menu enables the configuration of the protocols for connection with the alarm receiving centres CONTACT ID and CESA 200 BAUD. To program the parameters of these protocols, request a copy of the specific manual "Digital Protocols" from the Nice Service Centre.

### 6.2.7 - PC REMOTE MANAGEMENT

(advanced setting, without vocal guide)

The control panel enables remote technical assistance. For this function, the control panel must be connected to the PSTN telephone network, while the service centre must be equipped with the relative HSMO telephone modem and relative software for PC Tele Service.

Remote assistance must in any event be explicitly activated by the user by pressing the "spanner"  key.

To program the parameters required for remote technical assistance, refer to the relative manual of the HSMO telephone modem.

In general, the products in the range Nice Home Security do not require special maintenance; in any event the surfaces of the products should be cleaned, and in particular of the detectors, on which the sensitive elements (sensors) must be kept free of dust and other contaminating substances at all times (see respective instruction manual).

**Warning** – For cleaning the product surfaces, use a slightly damp (not wet) cloth; use water only and never detergents or solvents.

An alarm system does not normally signal alarm conditions for extended periods of time and for this reason correct operation is not always verified.

The control panel is equipped with a series of functions to maintain and check system efficiency:

- Possibility of checking components in the alarm system by means of the system “TEST” function (see chapter 9.2.5). Periodic checks of system operation are recommended.
- The control panel records all events and stores the last 200 events in the memory (see chapter 9.2.5.1). The analysis of the event log can be useful to check and possibly prevent the causes of malfunctions.
- The control panel indicates the charge level of a number of associated devices. All battery-powered devices have a function that checks the battery charge status; when the remaining autonomy is approx. 15-30 days, the “low battery” status is indicated. This occurs both on the device (see respective instruction manual) and on the control panel.

**Warning** – When the low battery signal is present, the battery must be replaced as soon as possible.

- The mains-powered devices have a rechargeable backup battery (not supplied) which is activated in the event of a power failure. The average lifetime of this battery is 4-7 years (decisive factors include environmental temperature, frequency and intensity of use).

It must be replaced at the end of this period. Otherwise a practical test of system duration must be performed: disconnect the mains power supply and check how long afterwards the low battery signal is activated. Replace the battery when the time is half that of the normal value or less than the required service time.

**Caution!** – When batteries are partially discharged, the radio range between devices is reduced and system operation is not guaranteed.

## 7.1 - Replacing the batteries (control panel and accessories)

When the battery pack or backup battery of the control panel or those in the accessories are discharged, they must be replaced to restore efficient system operation.

**Caution!** – Never use new battery models different from the specified version.

**Caution!** – To avoid inadvertent tamper alarms, before opening any device (control panel, siren, detectors) the “CONTROL PANEL TEST” mode must be enabled on the control panel (see chapter 9.2.5.1). **Caution!** - For safety purposes, the models HSCU1GC and HSCU1C should always be disconnected from the electrical mains.

To replace the control panel battery proceed as follows:

### For models HSCU1GC and HSCU1C (backup battery):

01. Open the box (fig. 41);
02. Detach the backup battery from its seat (fig. 42) and replace with an identical version. **Caution!** – Observe the indicated polarity;
03. Close the box (fig. 44);

### For models HSCU1G and HSCU1 (battery pack):

01. Open the box (fig. 41);
02. Detach the battery (fig. 43) and replace with an identical version.
03. Connect the new battery;
04. Close the box (fig. 44);

After closing the control panel, restart the control panel and reprogram at least the time and date for the internal clock (see chapter 6.1).

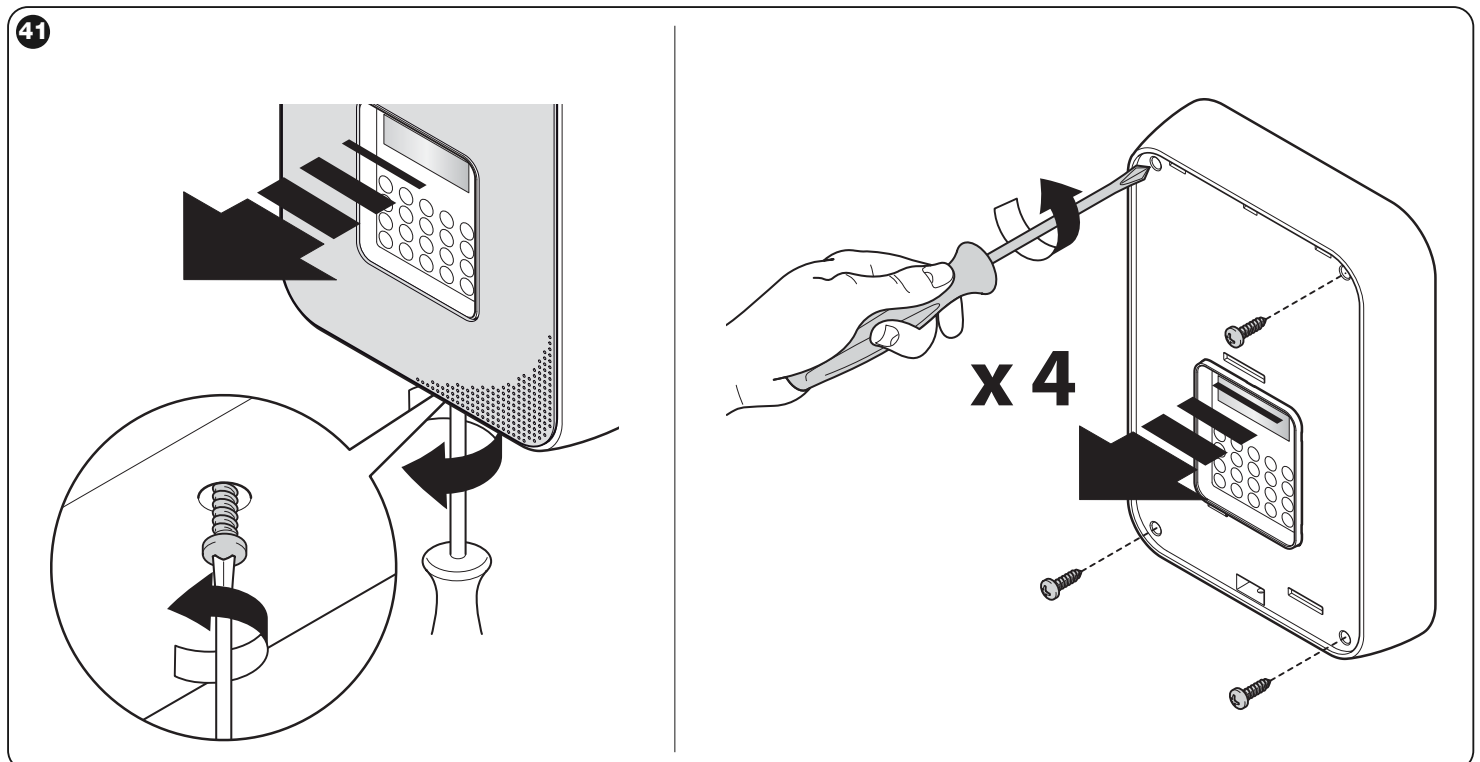

42

only for models HSCU1GC and HSCU1C

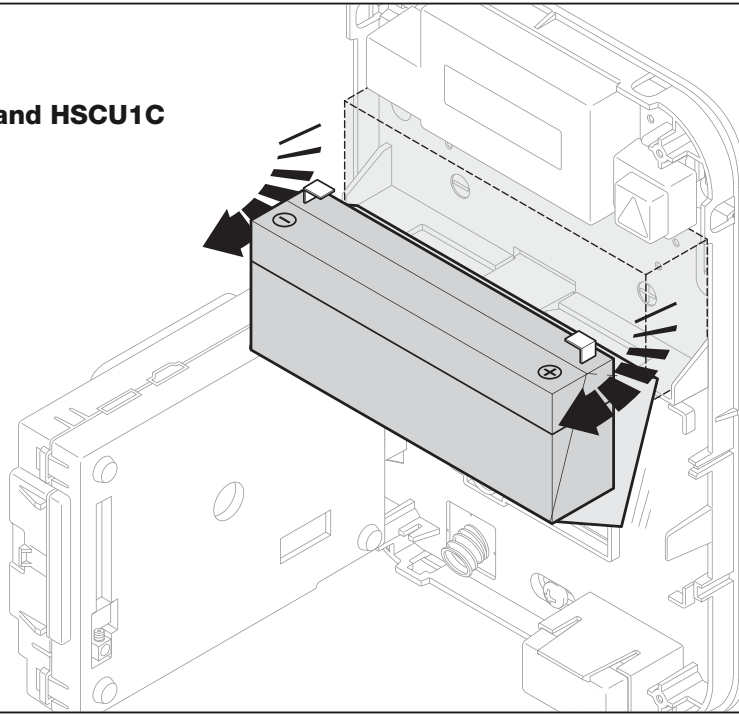

43

only for models HSCU1G and HSCU1

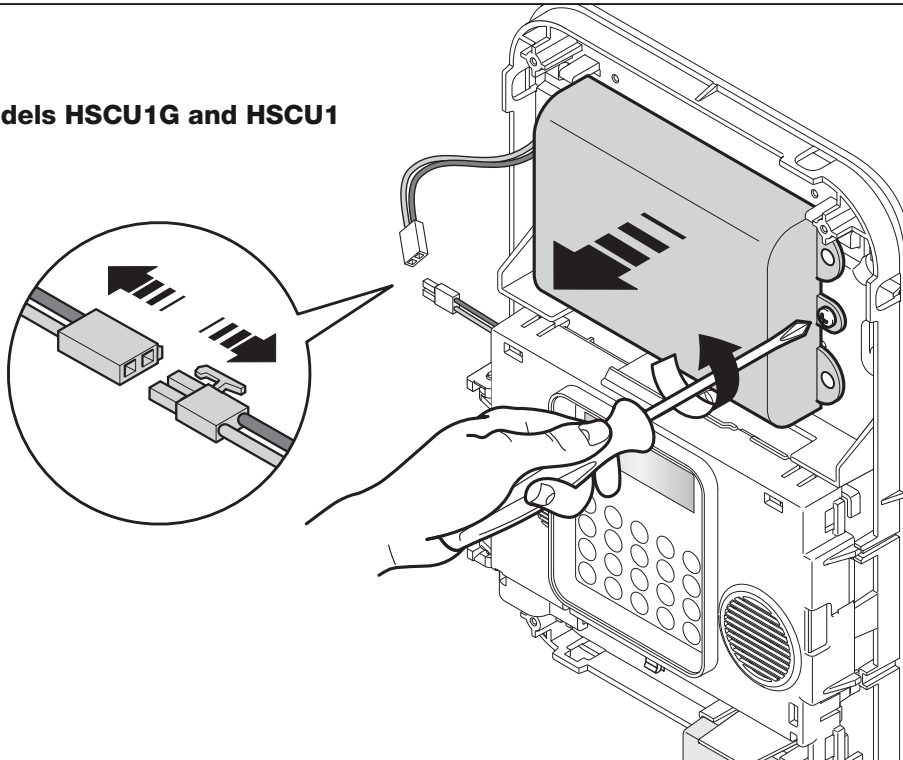

44

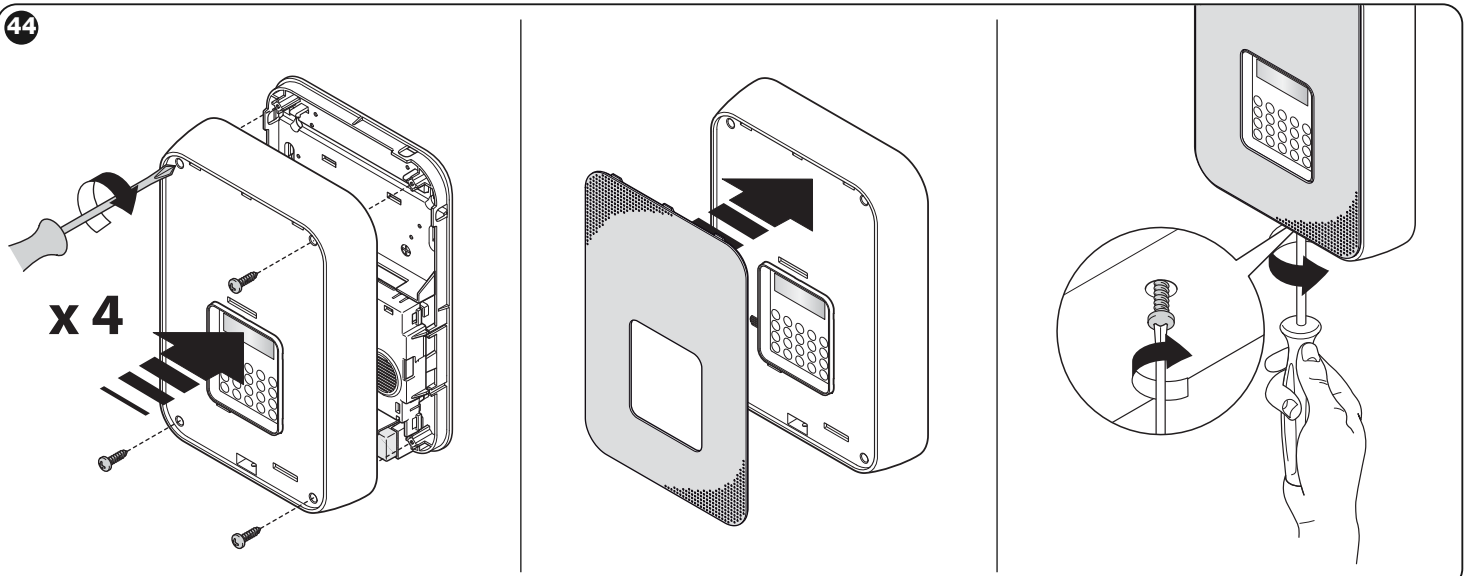



### • A detector occasionally generates an improper alarm:

- check whether the batteries are discharged;
- ensure that the detector is not dirty or damp.
- Check the specific instructions for each type of sensor for the possible causes of improper alarms and act accordingly. If the improper alarms persist, place a second detector in the same area to be controlled and memorise, associating it with the first, using the AND function.

### • A detector occasionally generates an improper alarm

These may be caused by a significant temperature variation and consequent deformation of surfaces. In this case disable the tamper device on the base, by means of the relative dip-switch.

#### **HSDID11: Door and window opening detector**

- **Incomplete door/window closure:** if the door or window is not perfectly closed, the wind may move it.
- **Door/window deformation:** check the correct distance between the sensor and magnet with the door/window closed
- **Vibrations:** the internal anti-intruder sensor is sensitive to strong vibrations
- **External contact:** the connection to the external contact is sensitive to high levels of humidity

#### **HSDIM11: Infrared detector with volumetric lens**

#### **HSDIM12: Infrared detector with curtain lens**

- **Strong currents of hot or cold air:** the infrared sensor is sensitive to hot moving bodies
- **Large insects:** for the sensor, a bumblebee of one centimetre would be like an elephant at a distance of 10 metres
- **Vibrations:** the internal anti-intruder sensor is sensitive to strong vibrations
- **External contact:** the connection to the external contact is sensitive to high levels of humidity

#### **HSDIS01: Fine volatile combustion powder detector**

- **Cooking fumes and vapours:** place the sensor far from cooking areas
- **Dust:** avoid positioning the sensor in dusty environments

#### **HSDID01: Glass breakage sensor**

- **Falling objects:** can cause noise similar to breaking glass
- **Rapid pressure changes:** the activation of air conditioners or fans can generate improper alarms.

#### **HSDIW01 : Flooding detector**

- **Condensation or high levels of humidity:** high levels of humidity can produce condensation on the sensor
- **Dirty sensor:** dirt increases the risk caused by humidity

• **Even when passing in front of a volumetric sensor, no alarm signal is triggered:** once a volumetric has transmitted the first alarm, it will not transmit another if repeated within 3 minutes. Wait for at least 3 minutes and then try again.

#### • For all products in the Nice Home Security system

Virtually all products are fitted with protection against opening and removal; this system normally acts on the cover and base of the product. Inadequate fixture or incorrect closure of the covers could cause an alarm signal; this is a rare case for example in the case of temperature variations.

#### • The display shows: DISARM AND INSERT SIM

- Ensure that the SIM card is inserted correctly and if necessary disconnect the power completely and insert the SIM card.
- Ensure that the SIM card has not expired (some operators deactivate the SIM cards after a certain period of disuse) and in the case of pay-and-go mobile phones, check that there is residual credit.

#### • The display shows: PIN

Disconnect the power, remove the SIM card and using a mobile phone disable the PIN code request.

#### • Problems with the telephone diallers

To perform the dialler test, the voice and text messages must already be programmed.

- If the call on the GSM network is not made correctly, there may be problems with the GSM coverage; in this case use a different network provider or install the control panel in a location with better GSM coverage.
- If the call on the PSTN line is not made correctly (also on broadband) there may be disturbance on the telephone line: in this case, to override the call, enter the symbol \* before the telephone number, obtained by pressing ▲ (e.g. \*9876543).

## DISPOSAL

### Product disposal

All devices in the alarm system are an integral part of the installation and must be disposed of as a whole. As in installation, also at the end of product lifetime, the disassembly and scrapping operations must be performed by qualified personnel.

These products comprise various types of materials: some may be recycled others must be disposed of. Seek information on the recycling and disposal systems envisaged by the local regulations in your area for this product category.

**Caution!** – Some parts of the products may contain pollutant or hazardous substances which, if disposed of into the environment, may cause serious damage to the environment or physical health.

As indicated by the symbol alongside, disposal of this product in domestic waste is strictly prohibited.

Separate the waste into categories for disposal, according to the methods envisaged by current legislation in your area, or return the product to the retailer when purchasing a new version.

**Caution!** – Local legislation may envisage serious fines in the event of abusive disposal of this product.



### Disposal of batteries

**Caution!** – The backup batteries and battery packs in the devices present in this alarm system, also if discharged, contain pollutant substances and therefore must not be disposed of as household waste. Dispose of according to separate waste collection procedures as envisaged by local current standards.

## 9.1 - Tips when using the system





- Always activate the alarm.
- Always close doors and windows.
- Never leave evident signs that there is no one at home, for example a full letter box.
- If absent for long periods, remember to use the system functions that simulate your presence: for example use the internal timed programmer to temporarily open shutters or switch on some internal lights.
- At regular intervals change the alarm deactivation code without divulging it to others.

## 9.2 - Operations available to the user



### 9.2.1 - Total alarm system activation

- **Via the control panel keypad:** enter the numerical code then press the red key twice.
- **Via the supplementary keypads:** enter the numerical code then press the red key once (the Installer and User codes are not accepted).
- **Via the remote controls:** press the  key once.
- Automatic total alarm system activation can be programmed at a set time as required (see 6.2.5.5).
- Total alarm system can also be activated remotely, by means of a telephone call (see 9.2.9).

### 9.2.2 - Partial alarm system activation

- **Via the control panel keypad:** enter the numerical code then press the red key once. If zone A, B or C is not to be activated, press respectively keys 1, 2, or 3 to disable, then press the  key once.
- **Via the supplementary keypads:** enter the numerical code, then if zone A, B or C is not to be activated, press respectively keys 1, 2, or 3 to disable, and press the  key once (the Installer and User codes are not accepted).
- **Via the remote controls:** press the key (  ) to activate zones A+B. If the remote control is duly configured, press the key (  ) to activate zones B+C.
- Automatic partial alarm system activation can be programmed at a set time as required (see 6.2.5.5).
- Partial alarm system can also be activated remotely, by means of a telephone call (see 9.2.9).

### 9.2.3 - Alarm system deactivation

- **Via the control panel keypad:** enter the numerical code then press the  key once.
- **Via the supplementary keypads:** enter the numerical code then press the  key once (the Installer and User codes are not accepted).
- **Via the remote controls:** press the  key once.

### 9.2.4 - Alarm system deactivation under threat (anti-duress)



- **Via the control panel or supplementary keypads:** if the alarm system is deactivated by entering a special "antiduress" code, the alarm system is deactivated and specific telephone calls are transmitted automatically as envisaged for the robbery alarm.

**Caution:** if an alarm is in progress, the corresponding GSM calls may cause problems with deactivation of the alarm system via the supplementary keypads or remote controls. In this case the alarm system should be deactivated via the control panel keypad.



### 9.2.5 - Control panel test

The control panel test function enables a number of checks on system operation. For example the CONTROL PANEL TEST mode is useful to open devices and change the batteries, as in these conditions the sirens are temporarily disabled. There are 3 types of test:

- **CONTROL PANEL test:** enables the user to check operation of all detectors and quality of the radio signal received.
- **PHONE DIALLER Test:** enables delivery of one of the recorded messages on the fixed PSTN or GSM line.
- **FIELD METER Test:** enables the user to check signal intensity on the 2 frequencies used by the system and any radio disturbance in the environment. To activate the test modes, proceed as follows:

- 01.** With the control panel disarmed, enter the user or installer code and press .
- 02.** The word TEST is shown on the first line of the display and CONTROL PANEL on the second line.
- 03.** Press **OK** to confirm and proceed with the control panel test or use keys  and  to display the other types of test. Press **OK** again to confirm.
- 04.** According to the type of test selected, proceed according to the procedure in one of the following three paragraphs.

### 9.2.5.1 - CONTROL PANEL test

- 05.** Generate a detector alarm by opening protected doors and windows or moving within the area protected by the volumetric detectors etc.
- 06.** Wait for at least 5 seconds between one alarm and the next; on completion ensure correct reception of each alarm, scrolling through the list on screen using keys  .

Example: if the display shows:

**ALL SENSOR**  
**03 C1H C2M**

this means:

|        |  |
|--------|--|
| ALARM  | alarm  |
| SENSOR | name assigned to detector                        |
| 03     | progressive number (3rd event detected)          |
| C1 H   | radio signal on frequency C1 high (H = high)     |
| C2 M   | radio signal on frequency C2 medium (M = medium) |

The quality of the signal depends on the distance between devices and any obstacles present; the signal is encoded on 3 levels: H (high); M (medium); L (low). These 3 levels are sufficient to guarantee correct operation of the detector. If **one** frequency has no display, the detector is probably outside the maximum range or there is disturbance on this frequency; in any event a single frequency should still be sufficient to guarantee correct system operation.

However if **both** frequencies display nothing, a practical test must be made by arming the control panel and generating the alarm. Technical practices envisage the TEST when the signal is weak: in normal conditions the system should continue to be operative.

A detector signal may at times be high (H) and at others medium (M): this may depend on random interference or the movement of persons in the area during testing. This often occurs with remote controls as their position with respect to the control panel can easily change.

#### Notes on control panel testing:

- Some detectors transmit the alarm twice; therefore there may be two consecutive signals on the list.
- Once a volumetric detector has transmitted the first alarm, it will not transmit another if repeated within 3 minutes. To perform the test, there must not have been persons within the protected area for at least three minutes. This block, on repetition of the alarm within 3 minutes, is not present if the detector battery compartment is open. Therefore the test should be performed with the battery compartment open.

### 9.2.5.2 - FIELD METER test

- 05.** Transmit a radio signal using any device and immediately check intensity of the signal received for the 2 frequencies.

Example: if the display shows:

**C1: ■■■■**  
**C2: ■■■■**





this means:

|    |  |
|----|--|
| C1 | signal on frequency 433 MHz: excellent (*) |
| C2 | signal on frequency 868 MHz: very good (*) |

(\*) **Note** – The signal is sufficient if more than one bar is displayed.

**Caution!** - The constant presence of radio signals on the two frequencies (C1 and C2) implicates radio disturbance which may impair correct system operation.



### 9.2.5.3 - PHONE DIALLER test

- 05.** Dial the number to be called and press **OK** to confirm:
- 06.** Using keys  , select a message to send, from those previously configured, and press **OK** to confirm.
- 07.** Using keys  and  select whether to use the PSTN line or GSM network.
- 08.** Press **OK** again to confirm: the call is made.
- 09.** The message should be heard clearly from the number called.

### 9.2.6 - Event log

The control panels record all events occurred (arming, disarming, alarms etc.), memorising the date, time, name of the person performing the operation and the device concerned.

The memory stores the last 200 events; these are queued, and the 201st event then overwrites the 1st and so on. To check the event list, proceed as follows:

- 01.** Enter the user code and press .
- 02.** The display shows the most recent event; the first line shows the date and time and the second line displays a description of the event. The events are shown in abbreviated form; for an explanation of their meanings, refer to **examples 1, 2 and 3**.
- 03.** To display the other events, use keys  and .
- 04.** To quit, press **ESC**.

### EXAMPLE 1

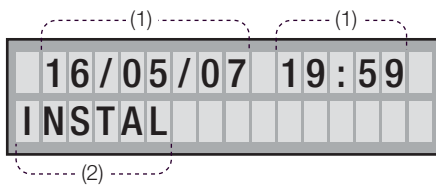

### EXAMPLE 1 - key

| n°  | Display        | Meaning  |
|-----|----------------|--|
| (1) |                | date/time of event                                   |
| (2) | INSTALL        | access to menu with installer code                   |
|     | USER           | access to menu with user code                        |
|     | NO PSTN LINE   | no connection to PSTN telephone line                 |
|     | NO GSM NETWORK | no connection to GSM network                         |
|     | MAINS FAILURE  | no power supply from mains                           |
|     | CHANGE NUM.    | modification via SMS of a phone number in phone book |
|     | GSM CHECK      | GSM activation-deactivation procedure                |

### EXAMPLE 2

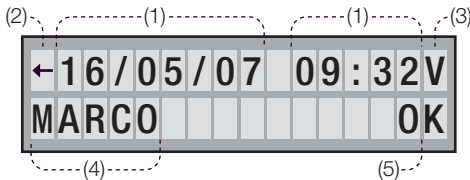

### EXAMPLE 2 - key

| n°  | Display     | Meaning                                       |
|-----|-------------|---|
| (1) |             | date/time of call                             |
| (2) | ←           | outgoing call                                 |
|     | →           | incoming call                                 |
| (3) | V           | vocal message                                 |
|     | S           | SMS message                                   |
|     | D           | message in digital protocol                   |
| (4) | (name)      | name of call recipient (stored in PHONE BOOK) |
|     | CONTACT ID  | call to alarm receiving centre                |
|     | INSTALLER   | remote assistance call                        |
|     | CUST. SERV. | call from service centre                      |
| (5) | OK          | call successful                               |
|     | KO:         | call failed                                   |
|     | OC          | call failed as engaged                        |
|     | NO:         | call failed as no answer                      |

### EXAMPLE 3

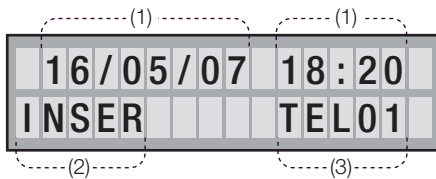

### EXAMPLE 3 - key

| n°  | Display          | Meaning                            |
|-----|------------------|------------------------------------|
| (1) |                  | date/time of event                 |
| (2) | ARM              | total arming                       |
|     | IN A (or B or C) | partial arming                     |
|     | DISARM           | disarming                          |
|     | EXT AL           | external alarm                     |
|     | OPEN             | door/window open                   |
|     | TAMPER           | tampering                          |
|     | ALARM            | alarm                              |
|     | PROGR.           | programming                        |
|     | SUPERV           | supervision failure                |
|     | SCAN             | radio disturbance                  |
|     | BATT             | battery discharged                 |
|     | DELETE           | deletion                           |
|     | EXCLUD           | out of service                     |
|     | INCLUD           | in service                         |
|     | Xxxxx (label)    | name assigned to peripheral        |
| (3) | TEL              | remote control                     |
|     | COD              | keypad code                        |
|     | DET              | sensor/detector                    |
|     | WIR              | wired input                        |
|     | USER             | access to menu with user code      |
|     | INSTAL           | access to menu with installer code |
|     | REMOTE           | intervention via remote telephone  |

## 9.2.7 - Timed program

The control panels HSCU1GC and HSCU1C are equipped with 1 relay output which can be used to control electrical appliances. Activation can be via a command sent by means of a telephone call (see 9.2.9) or automatically at a set time. In this case the activation start and end time can be programmed as follows:

01. With the control panel disarmed, press **ESC**.
02. The first line of the display shows TIME ON : 00:00; the second line displays TIME OFF: 00:00.
03. Use the numerical keys to enter the required times and press **OK** to confirm.

After programming the times, the function is enabled by pressing the UP arrow key [▲] in the main menu when the control panel is disarmed. The top left corner of the display shows the symbol "H" to indicate that the timed program is active and the relay output will therefore be activated every day at the set times. To disable the timed function press the DOWN arrow key [▼] (the "H" symbol disappears from display).

## 9.2.8 - Remote assistance

If the installer has the specific telephone modem, a PC and relative software, the control panel can be controlled at a distance to analyse and solve any problems.

The remote control must be activated by the user by pressing the holding the Ⓢ key for more than 5 seconds so that the control panel makes the call the telephone number entered by the installer. During connection, the user must avoid intervening on the control panel keypad to avoid any conflict. The user can still monitor operations in progress on display.

**Warnings for the installer** - A special access code can be configured (in the Remote management menu) to enable automatic access by the installer to the control panel. However the installer must bear in mind that this operation can be performed without the presence of the user and that it causes system deactivation (though only temporary). As this is the specific responsibility of the installer, a previous agreement is recommended between the installer and user to authorise use of the remote assistance provision without the user. In any event the user can disable this function at any time by cancelling the access code.

## 9.2.9 - Remote use

All control panels can be called via the telephone, on the fixed line, by dialling the relative number. The control panel HSCU1GC can also be called on the GSM network, by dialling the number of the SIM card used.

The control panel HSCU1G, though equipped with the GSM module, cannot receive calls as this module is normally switched off to reduce battery consumption.

### Calling the control panel on the fixed line

**Caution!** - To answer incoming calls on the PSTN line, the guide message N° 7 must be present (see paragraph 6.2.2); without this message, the control panel ignores the call.

To call the control panel, proceed as follows:

01. Dial the control panel telephone number.
02. Interrupt the call after the second ring.

03. Call again immediately, the control panel answers with vocal message N° 7.
04. After listening to the message, enter the user code on the telephone keypad, followed by the symbol #.
05. Then enter the command required (see Table A).

TABLE A

|           |  |
|-----------|--|
| 0 #       | Querying control panel status with vocal reply                                     |
| 0 * 1 #   | Total arming and vocal confirmation  |
| 0 * 2 #   | Partial arming (zones A+B only) and vocal confirmation                             |
| 0 * 0 #   | Disarming and vocal confirmation   |
| 2 0 * 1 # | (*) Activation of relay N° 1   |
| 2 0 * 0 # | (*) Deactivation of relay N° 1   |
| 2 0 #     | Check of status of relay N°1 (3 Beeps = relay active; 1 Beep = relay deactivated)  |
| 2 1 * 1 # | (*) Activation of relay N° 2   |
| 2 1 * 0 # | (*) Deactivation of relay N° 2   |
| 2 1 #     | Check of status of relay N°2 (3 Beeps = relay active; 1 Beep = relay deactivated)  |
| X X * 1 # | Delivery of radio control ON command to receiver N° XX (enter digit from 1 to 16)  |
| X X * 0 # | Delivery of radio control OFF command to receiver N° XX (enter digit from 1 to 16) |

(\*) **Note** - the command sent with a telephone call has priority over other envisaged commands; for example timed settings of relay 1.

### Calling the control panel on GSM module (HSCU1GC only)

The GSM module responds immediately to the incoming calls only if the called ID is recognised (the telephone must be enabled to send its own ID). It is also possible to avoid sending the user code, by enabling direct access for specific caller numbers (see PHONE BOOK – DIRECT ACCESS).

If the caller phone does not send its own number, or if the number is not enabled for direct access, refer to the previous procedure "Calling the control panel on the fixed line" for calling the GSM module.

#### 9.2.10 - User called by the control panel

In the event of an alarm, the control panel makes the envisaged telephone calls. Those called can interact with the control panel, for example to disarm it by entry of the command described in Table A.

Those called by the control panel can interrupt the cycle of envisaged calls (consecutive); to stop the calls, listen to the message and the end confirmation beep and then press the # key on the telephone.

#### 9.2.11 - Remote listening

Both when called by the control panel and when the user calls the control panel, during connection on the PSTN fixed line, the user can listen to the environmental noise captured by the control panel microphone.

To enable this function, press \* on the telephone. Press \* again to stop listening and proceed with sending any commands as required. If no operation is performed, the call is terminated after 60 seconds from ending the remote listening function.

#### 9.2.12 - Hands free conversation

(HSCU1GC and HSCU1G only, with control panel disarmed)

Both when called by the control panel and when the user calls the control panel, during connection on the GSM network, the user can set communication to hands-free mode from the microphone and loudspeaker of the control panel.

To enable this function, press \* on the telephone. Press \* again to stop listening and proceed with sending any commands as required. If no operation is performed, the call is terminated after 60 seconds from ending the remote listening function.

A telephone call can also be initiated using the built-in GSM. To enable this function, proceed as follows:

01. Press the key (📞) to connect.
02. Dial the number to be called and press OK to confirm:
03. To terminate the call, press ESC or the key (📞).

**Caution!** - The control panel HSCU1G enables the call, but the user must wait for the GSM module to switch on and connect to the network.

#### 9.2.13 - Remote modifications to stored telephone numbers

(HSCU1GC only)

It is possible to change the phone numbers in the phone book by means of an SMS message sent from a telephone memorised and enabled for direct access. To perform this operation, write the SMS message **without spaces** as follows: A[old number to replace]A[new number to enter] for example: A33355666A33377888

The control panel sends the following confirmation SMS message: "CHANGE MADE \*33377888"

#### 9.2.14 - Other functions on the GSM module

The control panels with GSM module offer other automatic functions (if programmed by the installer), such as:

- SMS notifying of absence and return of mains power (HSCU1GC only).
- SMS for periodic notification that the control panel is operating correctly.
- SMS notifying of SIM expiry.
- SMS notifying of low battery charge in devices.
- SMS notifying of control panel arming/disarming.

#### 9.2.15 - Residual credit on SIM

Press (📞) to make an automatic call to the service centre of the telephone operator and listen to an automatic message informing the user of the residual credit on the SIM card (the function must be configured accordingly (see 6.2.1).

## TECHNICAL SPECIFICATIONS

| <b>Technical specifications for models HSCU1GC and HSCU1C</b> |  |
|---|--|
| <b>Power supply</b>   | 230 V ~ 50 Hz; maximum power 35 W  |
| <b>Insulation</b>   | Class II (no earthing connection required)   |
| <b>Backup battery</b>   | 12V – 2.2Ah lead rechargeable (not supplied)   |
| <b>Backup battery autonomy</b>                                | With battery charged, approx. 36 hours; autonomy estimated with operation on stand by and without absorption on wired connections. |
| <b>External battery</b>                                       | An external battery can be connected (maximum 12 V - 6 Ah) on terminals +ALI and GND   |
| <b>Absorption (12Vdc)</b>                                     | 55mA on stand-by (without absorption on wired connections); 125mA with display lit; 500mA in alarm status.                         |
| <b>Power supply output</b>                                    | 12 Vdc ±30%; 1.2 A maximum total.  |
| <b>Wired alarm inputs</b>                                     | 6 lines for NC contacts, programmable on the 3 zones A-B-C   |
| <b>Wired anti-tamper device</b>                               | 3 lines for NC tamper contacts, programmable on the 3 zones A-B-C  |
| <b>Control inputs</b>   | 1 line for connection of supplementary arming device   |
| <b>Wired alarm outputs</b>                                    | 1 output for 12 V siren control, maximum 0.5 A; 1 output for self-powered siren 14 V   |
| <b>Wired outputs</b>  | 2 relay outputs (NC/C/NO contacts maximum 50 V-0.5 A) for programmable functions   |
| <b>Weight</b>   | 2,250 Kg   |

| <b>Technical specifications for models HSCU1GC and HSCU1</b> |  |
|--|--|
| <b>Power supply</b>  | Battery Pack HSPS1 (9 V ~12 Ah)  |
| <b>Insulation</b>  | Class III (safety extra low voltage)   |
| <b>Absorption</b>  | Approx. 200 µA on stand-by; maximum 200 mA in alarm status with PSTN operative; maximum 400 mA in alarm status with GSM operative  |
| <b>Autonomy</b>  | At least 2 years; autonomy estimated with 2 on/off cycles per day, 10 detectors present and 10 alarms per year. Autonomy is reduced in the event of numerous telephone calls |
| <b>Weight</b>  | 1,500 Kg   |

| <b>Technical and additional specifications for models HSCU1G and HSCU1GC</b> |   |
|--|---|
| <b>GSM telephone connection</b>  | GSM module, Quad-band, EGSM 850/900/1800/1900 MHz<br>Output power: - Class 4 (2W) at 850 / 900 MHz - Class 1 (1W) at 1800 / 1900 MHz Sensitivity: - 107 dBm at 850 / 900 MHz - 106 dBm at 1800 / 1900 MHz |
| <b>Additional functions</b>  | Delivery of technical or alarm SMS messages.<br>Caller ID recognition (for direct access).<br>Hands-free communication  |

| <b>Technical specifications common to all models (HSCU1G, HSCU1, HSUC1GC, HSCU1C)</b> |  |
|---|--|
| <b>Alarm via radio inputs</b>   | Up to 99 programmable detectors: immediate, delayed or AND, on 3 activation zones A-B-C or in 24-hour zones Panic, Robbery, Technical Alarm.                               |
| <b>Anti-tamper via radio</b>  | Reception of tamper signal from each detector; reception of supervision and low battery signals.   |
| <b>Alarm via radio outputs</b>  | Digital transmission encoded at 72 bit, for alarm device control.  |
| <b>Radio system anomalies</b>   | Continuous, simultaneous and programmable control of 2 working frequencies.  |
| <b>Event log</b>  | Last 200 events  |
| <b>Timers</b>   | Programmable delayed activation; programmable input delay on each detector; general alarm time 3 minutes (fixed).  |
| <b>Displays</b>   | Display 2 x 16 characters, with option of naming each peripheral (label).  |
| <b>Commands</b>   | Built-in alphanumeric keypad, 20 keys.   |
| <b>Internal siren and indicator</b>   | Alarm siren 106 db + buzzer with low intensity signal function.  |
| <b>Acoustic signals</b>   | Vocal messages recordable on 32 Mbit flash memory for approx. 500 s of messages. Digitalised PCM user guide at 64 Kbps. Main communication guidelines for the user.        |
| <b>Vocal guide</b>  | Vocal synthesis with 125 pre-recorded "phrases", available in the main languages.  |
| <b>Radio reception/transmission</b>   | Digital bidirectional communication, in dual band frequency (433 and 868 Mhz) with quartz control; devices pre-encoded in the factory and managed in self-learning mode.   |
| <b>Radio range</b>  | 100m in open field free of disturbance or approx. 20 m inside buildings.   |
| <b>Fixed PSTN telephone connection</b>  | Connection with standard RJ14 socket. Automatic adaptation to line characteristics in country of use, according to the selected language. Compatible with broadband lines. |
| <b>Dimensions</b>   | 307 x 200 x 53 mm  |
| <b>Operating temperature</b>  | from -10°C to +40°C  |

# CE DECLARATION OF CONFORMITY

Declaration in accordance with Directive 1999/5/EC

**Note** - The contents of this declaration correspond to declarations in the official document deposited at the registered offices of Nice S.p.a. and in particular to the last revision available before printing this manual. The text herein has been re-edited for editorial purposes. A copy of the original declaration can be requested from Nice S.p.a. (TV) I.

**Number:** 305/HSC...      **Revision:** 0      **Language:** EN

The undersigned, Luigi Paro, in the role of Managing Director, declares under his sole responsibility, that the product:

**Manufacturer's name:** NICE s.p.a.  
**Address:** Via Pezza Alta 13, Z.I. Rustignè, 31046 - Oderzo (TV) Italy  
**Product type:** Supervised control panels with provision for remote management, standard 230V mains power supply or battery powered; with or without GSM module  
**Model:** HSCU1GC, HSCU1C, HSCU1G, HSCU1  
**Accessories:**

Conforms to the essential requirements stated in article 3 of the following EC directive, for the intended use of products:

- Directive 1999/5/EC OF THE EUROPEAN PARLIAMENT AND COUNCIL of 9 March 1999 regarding radio equipment and telecommunications terminal equipment and the mutual recognition of their conformity according to the following harmonised standards:
  - Health protection (art. 3(1)(a)): EN 50371:2002, EN50360:2001+A1:2006
  - Electrical safety (art. 3(1)(a)): EN 60950-1:2006
  - Electromagnetic compatibility (art. 3(1)(b)): EN 301 489-1 V1.8.1:2008, EN 301 489-3 V1.4.1:2002, EN301489-7 V1.3.1:2005
  - Radio spectrum (art. 3(3)): EN 300 220-2 V2.1.2:2007, EN 301511 V9.0.2:2003

In accordance with the directive 1999/5/EC (appendix V), the product is class 1 and marked:

**CE 0682**

The product also conforms to the requirements of the following harmonised standards:

EN 50130-4:1995+A1:1998+A2:2003

Oderzo, 27 January 2011

**Luigi Paro**  
(Managing Director)



# QUICK GUIDE TO PROGRAMMING

Before powering up the control panel and starting programming, insert the memory board in the relative slot (**fig. A**) and the SIM card when envisaged (**fig. B**).

The SIM card must not be subject to limitations (PIN and blocks) to enable automatic operation (if it is not possible to remove the PIN number of the SIM, set the PIN number as 1234, by means of a mobile phone).

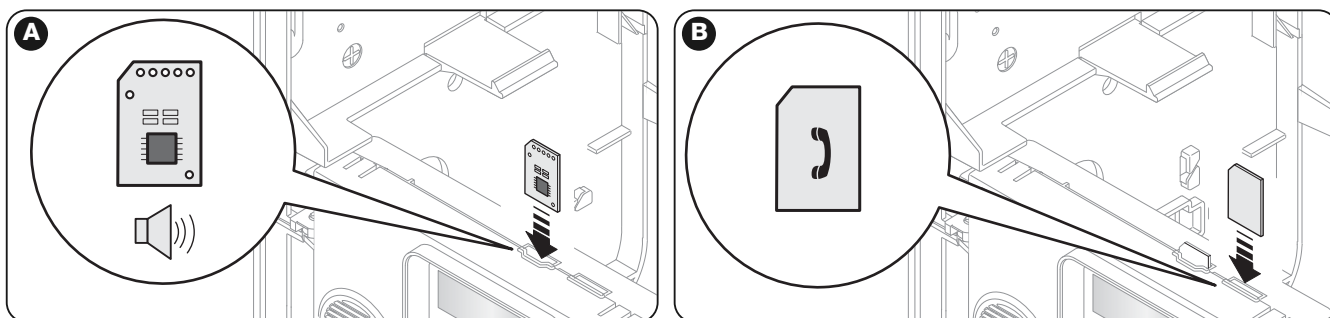

After making all the electrical connections (**fig. C**), proceed with device programming as follows:

- Power up the control panel;
- Select the menu language;
- Enter the **FACTORY CODE** (0000) followed by OK;
- Set the **TIME AND DATE**;
- Set the **USER CODE** (4/8 digits);
- Set the **INSTALLER CODE** (4/8 digits). **Important!** – the code must be different from the **USER CODE**.
- The programming menu is then displayed.

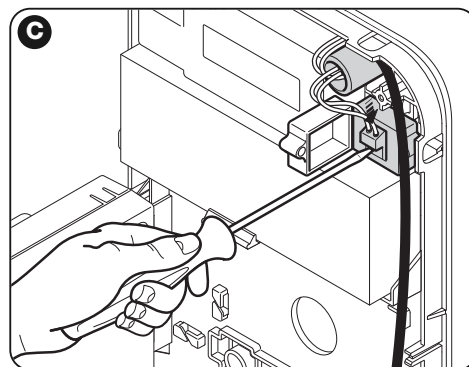

To access the programming menu, enter the **USER CODE** or **INSTALLER CODE**, followed by **OK**.

## Notes:

- To move within the menus, use keys ▲ ▼.
- When the required menu is found, press **OK** to select.
- To select zones A, B and C use numerical keys 1 to 6.

## COMPLETE MENU OF HSCU1 CONTROL PANELS

### Warnings:

- The **INSTALLER CODE** accesses all menus.
- The **USER CODE** accesses only the menus marked with an asterisk (\*).

| PHONE BOOK   | MESSAGES                                | EXTRAS   | SETTINGS   |
|--|---|--|--|
| MEMORY (*)<br>SEARCH NAME (*)<br>SEARCH POSITION (*) | VOICE MESSAGES (**)<br>SMS MESSAGES (*) | REMOTE CONTROLS (*)<br>CODES (*)<br>ALARM ZONE A<br>ALARM ZONE B<br>ALARM ZONE C<br>24H PANIC<br>24H ROBB.<br>24H TECHNOL.<br>WIRED INPUTS<br>EXTERNAL KEY (*) | EXCL. WIRED INP. (*)<br>SET RELAY 1 (*)<br>SET RELAY 2 (*)<br>RADIO CONTROLS<br>GSM-TEL LINE<br>MAINS FAILURE<br>PERIODIC CALL<br>SIM VALIDITY<br>TIME AND DATE (*)<br>TEL.<br>CODE (*)<br>ANTISCANNER<br>SUPERVISION<br>EXIT TIME<br>AUT. SUMMER H. (*)<br>BACK LIGHTING (*)<br>VOLUME (*)<br>OVERRIDE ACTIVATION (*)<br>FW VERSION (*)<br>SYSTEM RESET |



**Nice SpA**  
Oderzo TV Italia  
info@niceforyou.com

[www.niceforyou.com](http://www.niceforyou.com)