

RSC-T

CE

Tension Springs

3.000 x 2.250mm and a door weight of 75kg.

INSTALLATION / MAINTENANCE



Tension spring door RSC-T

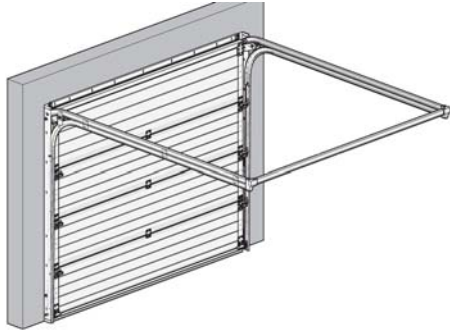

01 145 991 rev.30-03-2015

1

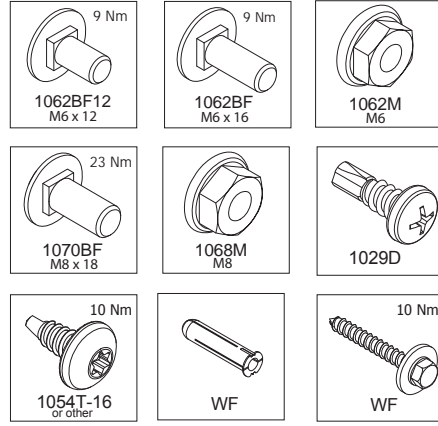

01 145 991 rev.30-03-2015

2

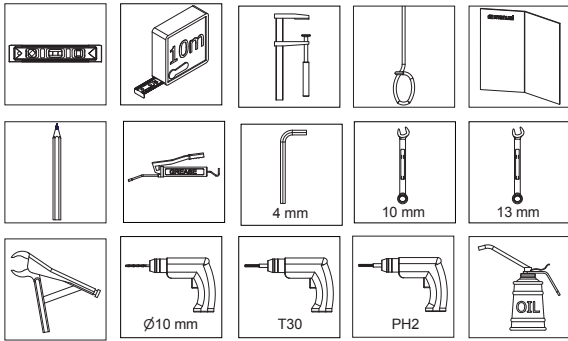

01 145 991 rev.30-03-2015

3

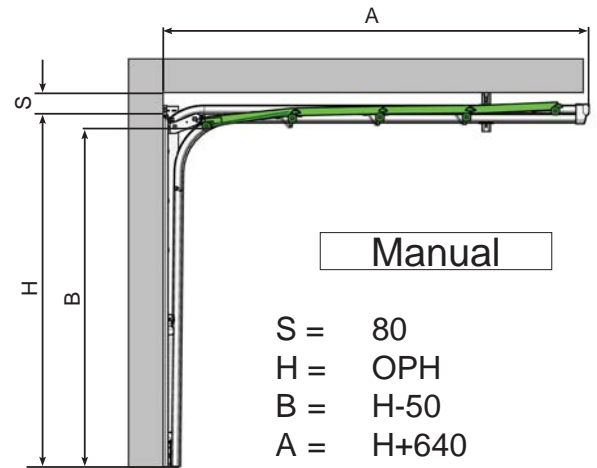

01 145 991 rev.30-03-2015

4

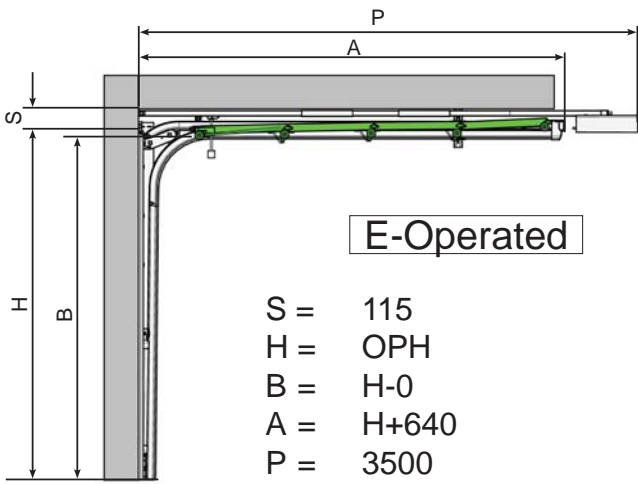

01 145 991 rev.30-03-2015

5

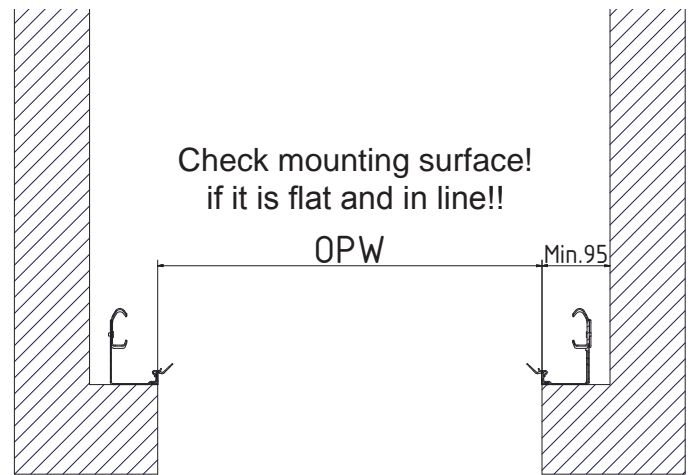

01 145 991 rev.30-03-2015

6

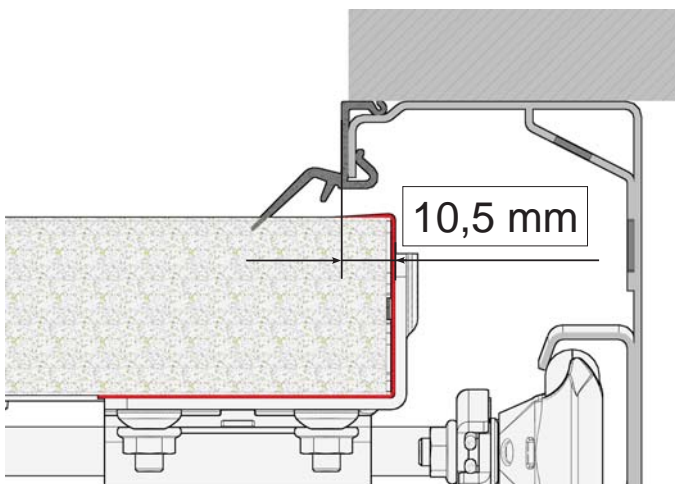

01 145 991 rev.30-03-2015

7

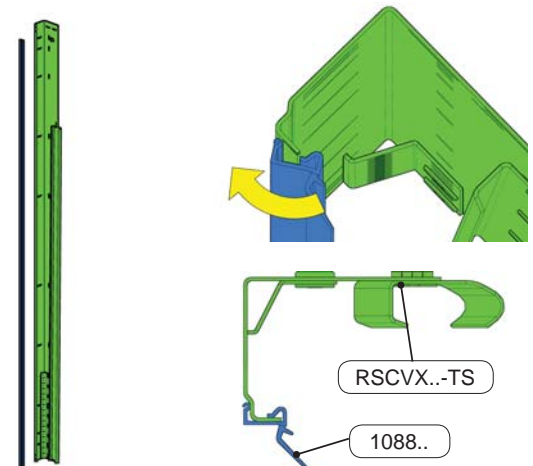

01 145 991 rev.30-03-2015

8

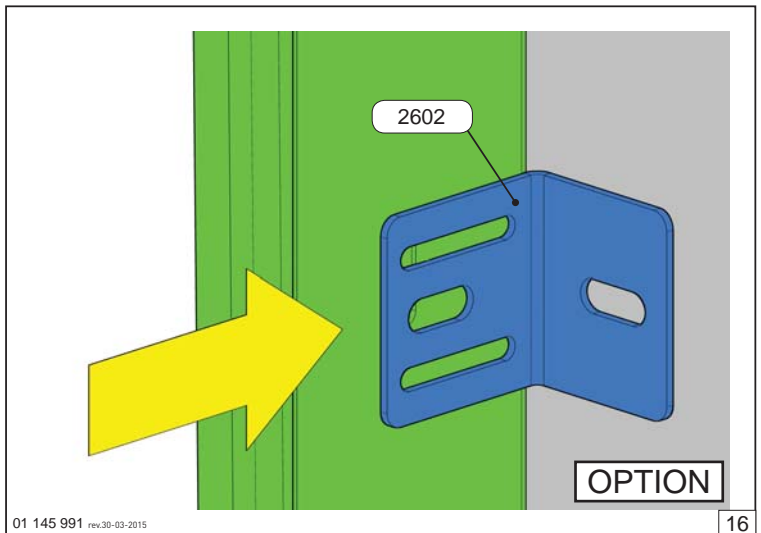
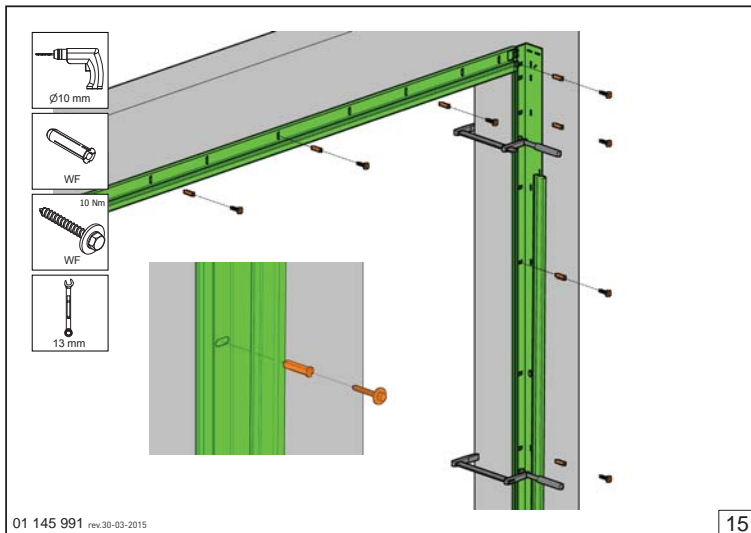
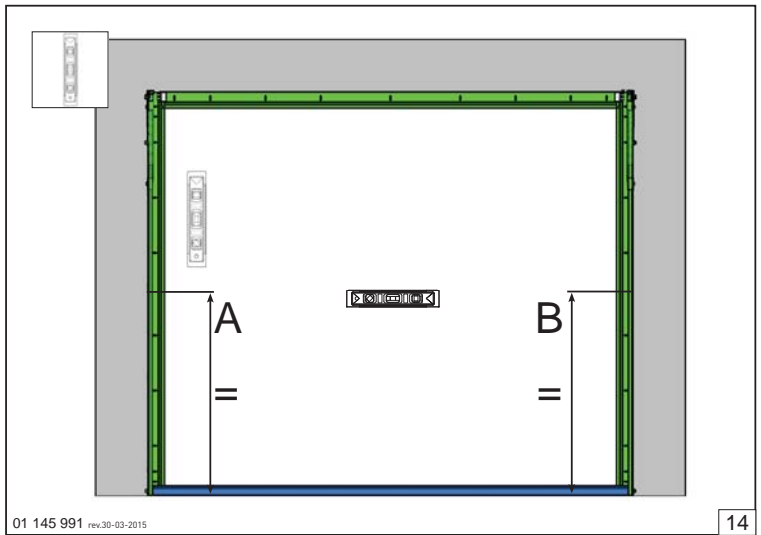
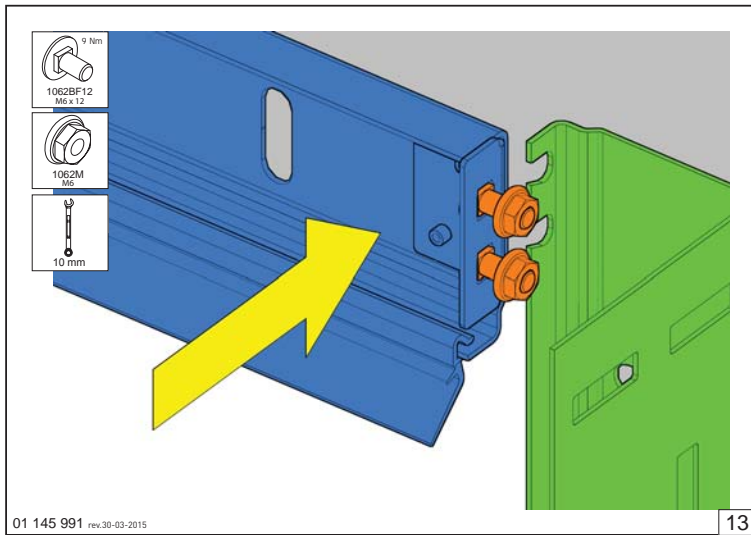
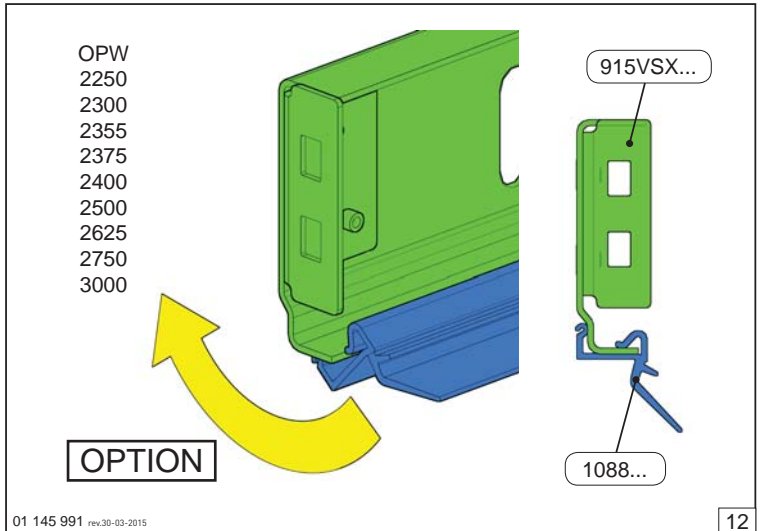
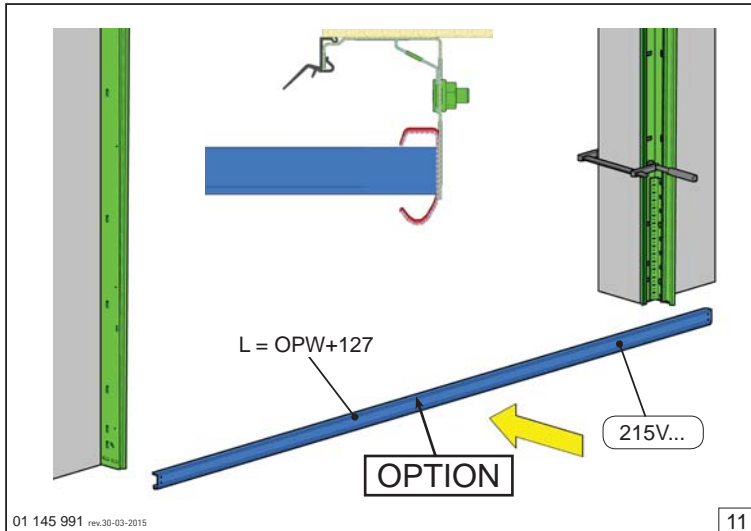
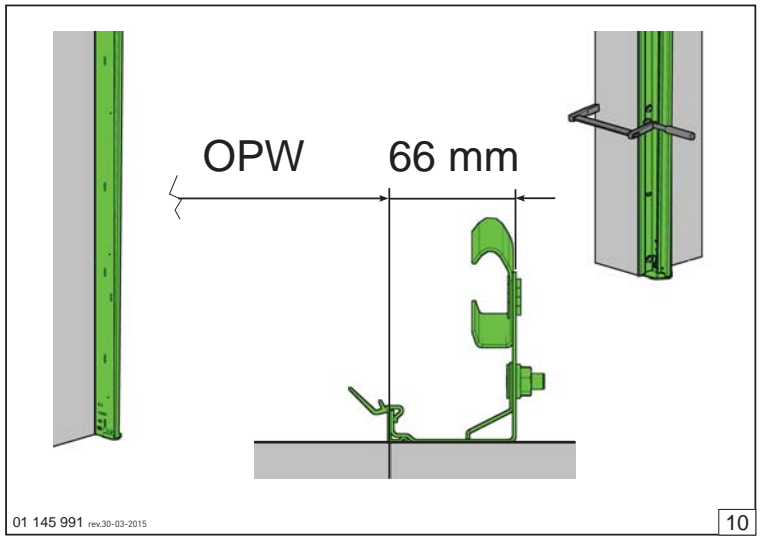
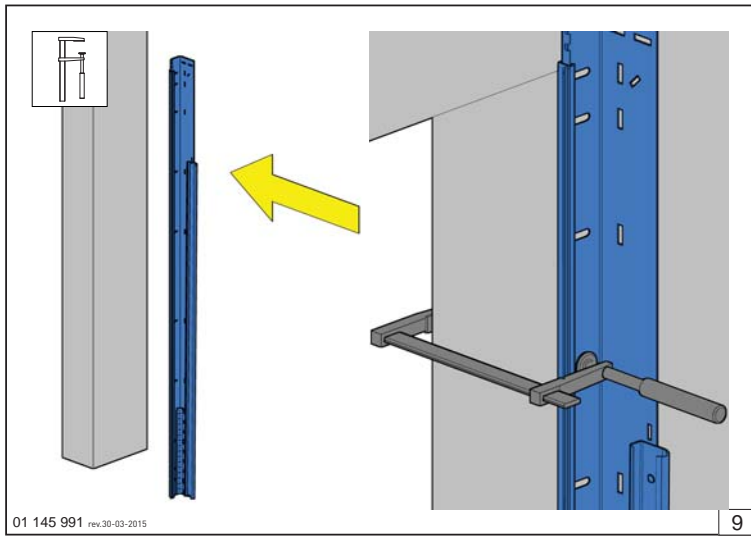

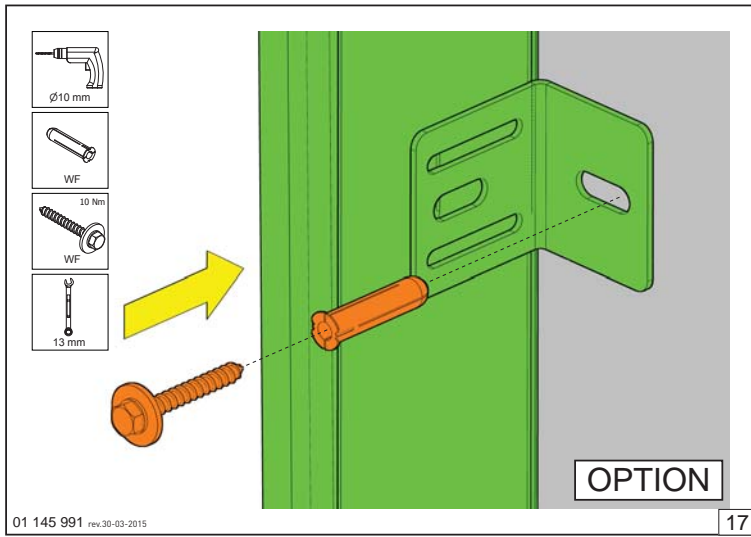

01 145 991 rev.30-03-2015

17

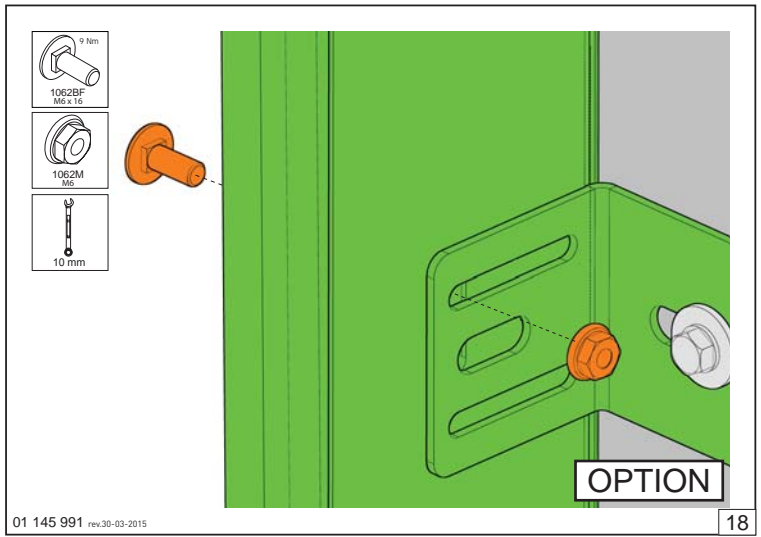

01 145 991 rev.30-03-2015

18

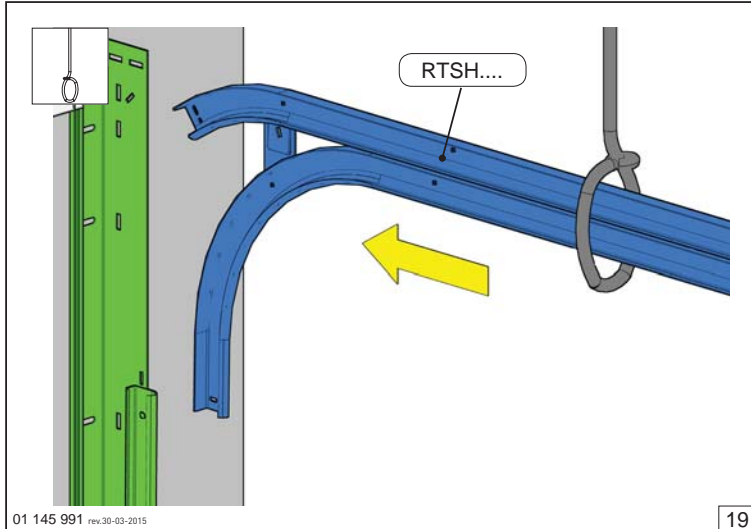

01 145 991 rev.30-03-2015

19

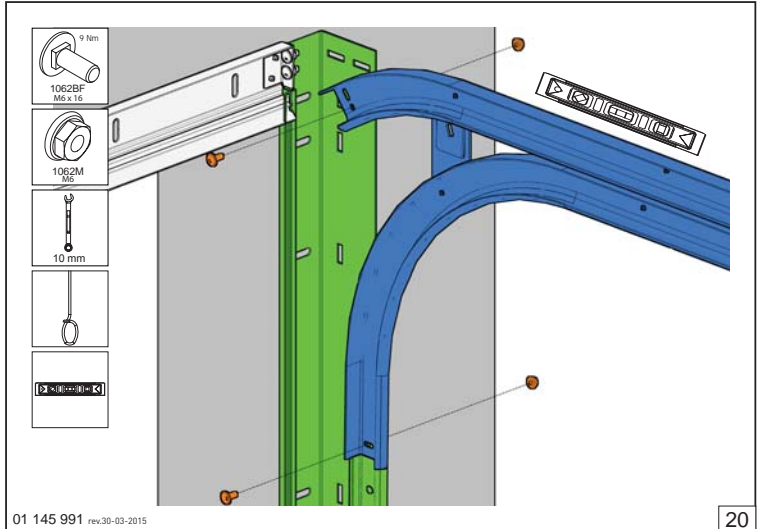

01 145 991 rev.30-03-2015

20

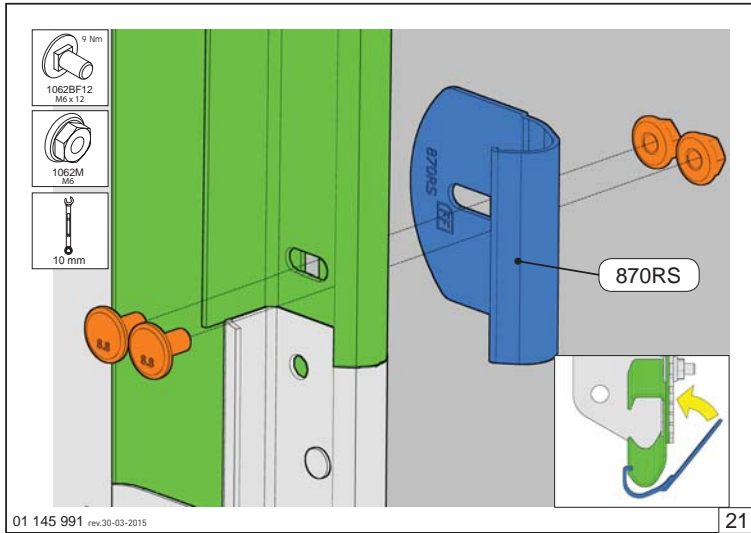

01 145 991 rev.30-03-2015

21

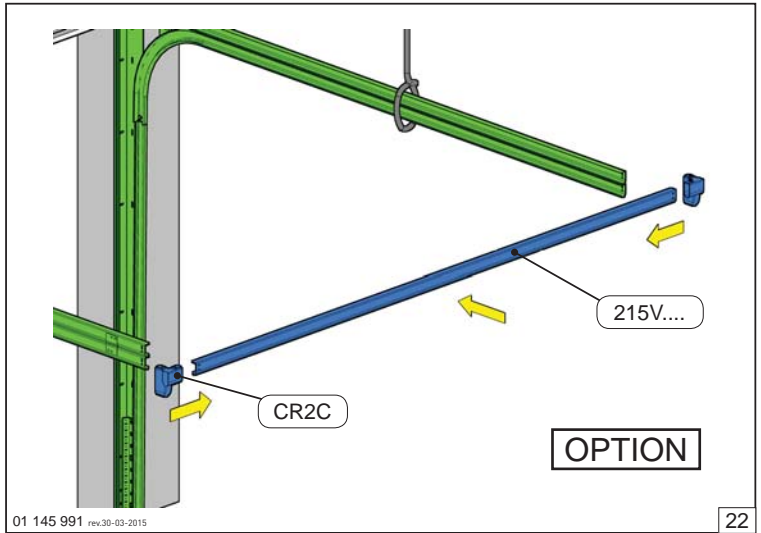

01 145 991 rev.30-03-2015

22

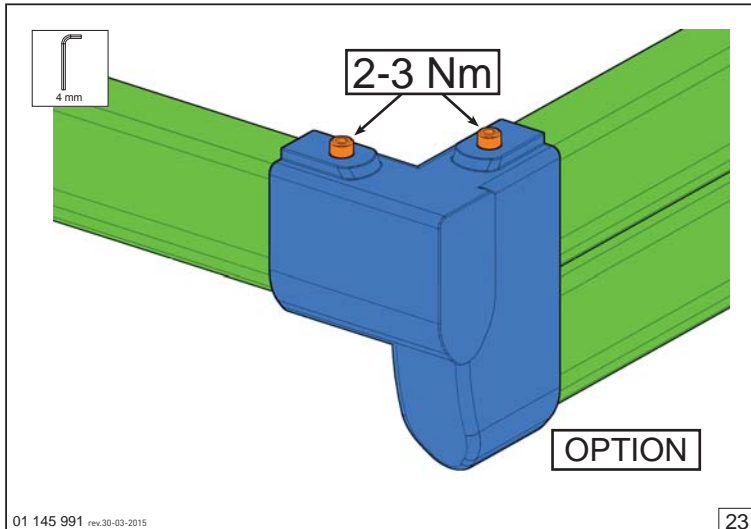

01 145 991 rev.30-03-2015

23

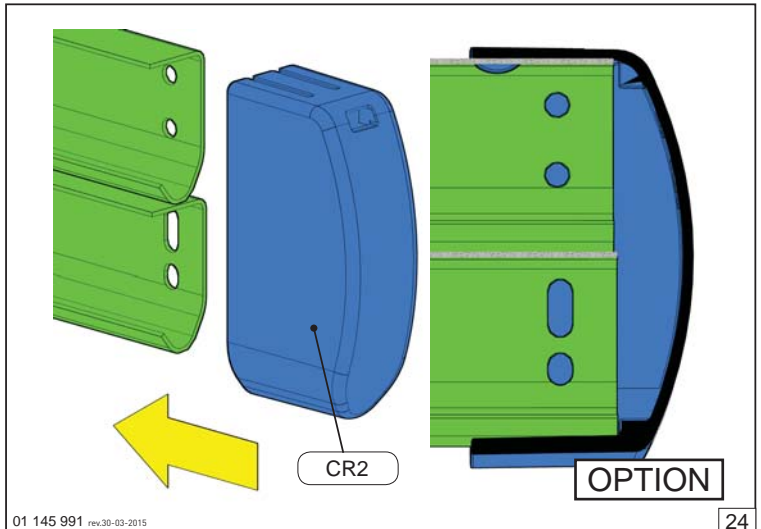

01 145 991 rev.30-03-2015

24

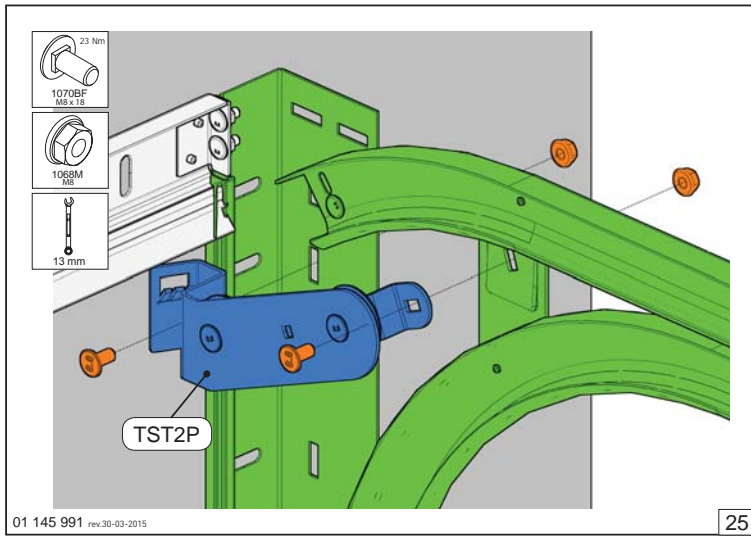

01 145 991 rev.30-03-2015

25

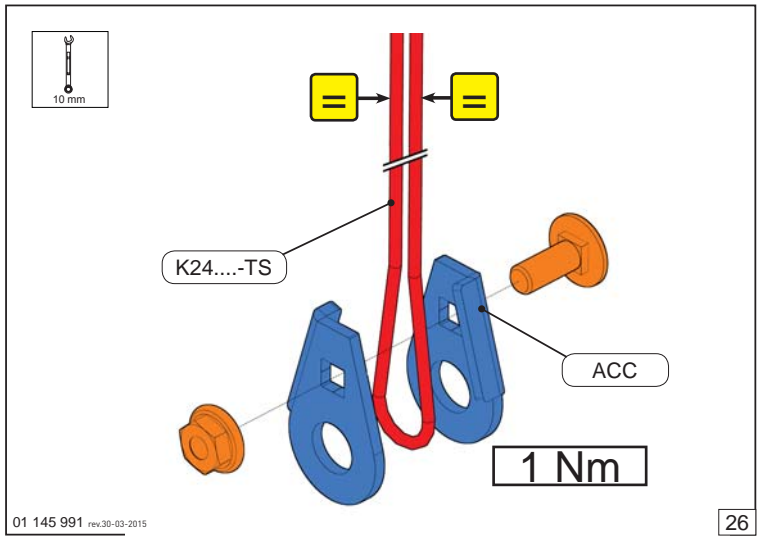

01 145 991 rev.30-03-2015

26

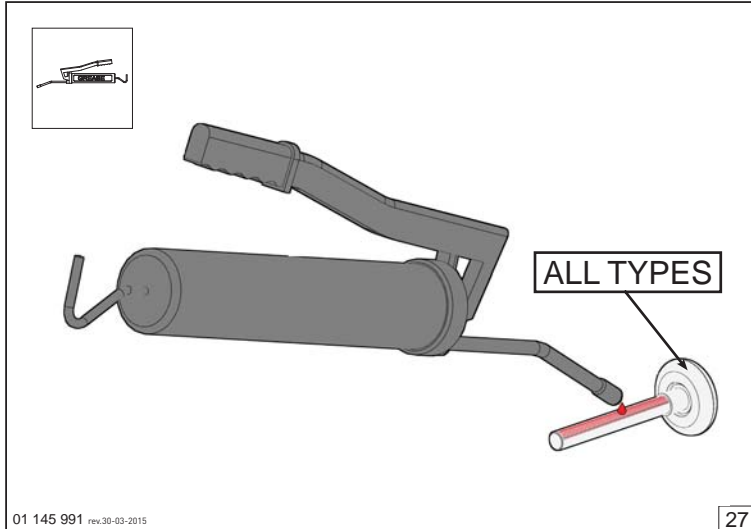

01 145 991 rev.30-03-2015

27

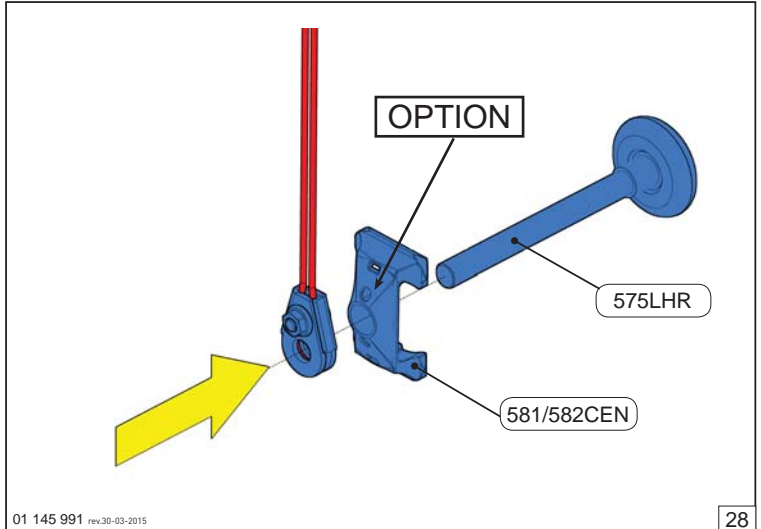

01 145 991 rev.30-03-2015

28

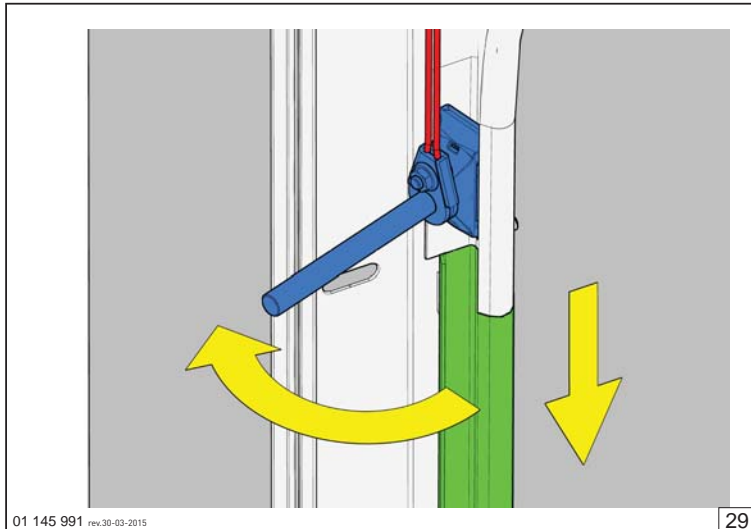

01 145 991 rev.30-03-2015

29

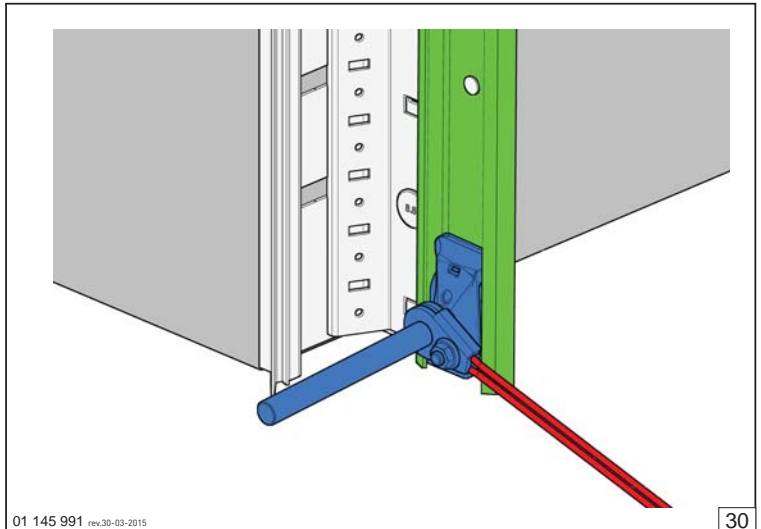

01 145 991 rev.30-03-2015

30

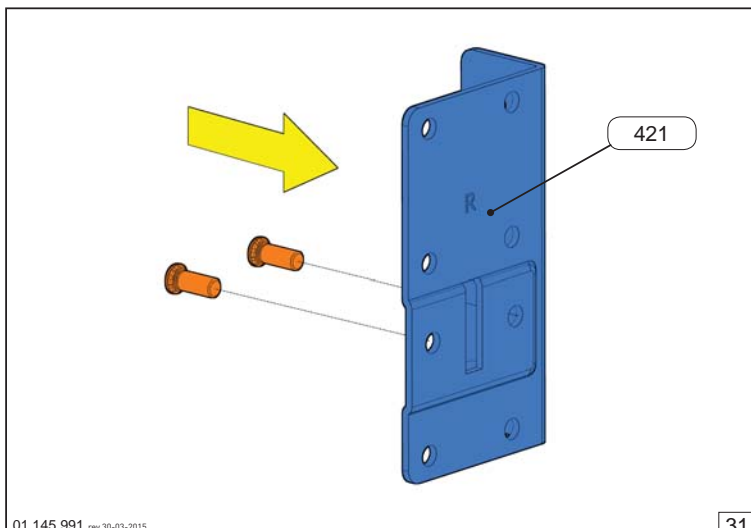

01 145 991 rev.30-03-2015

31

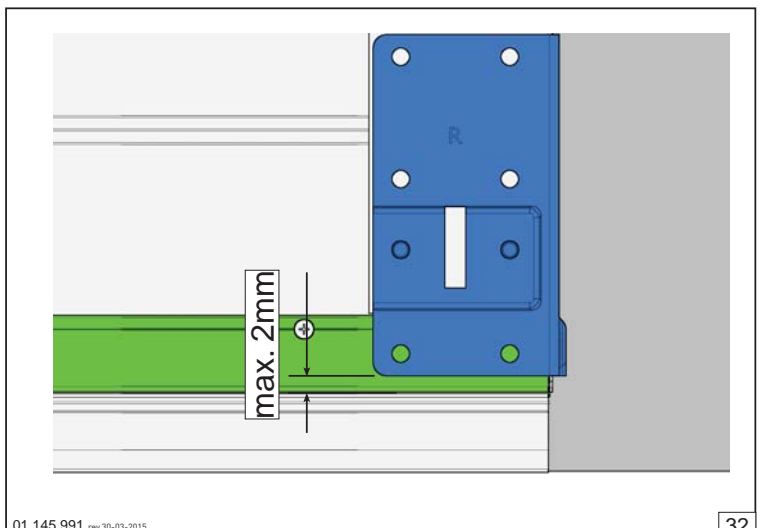

01 145 991 rev.30-03-2015

32

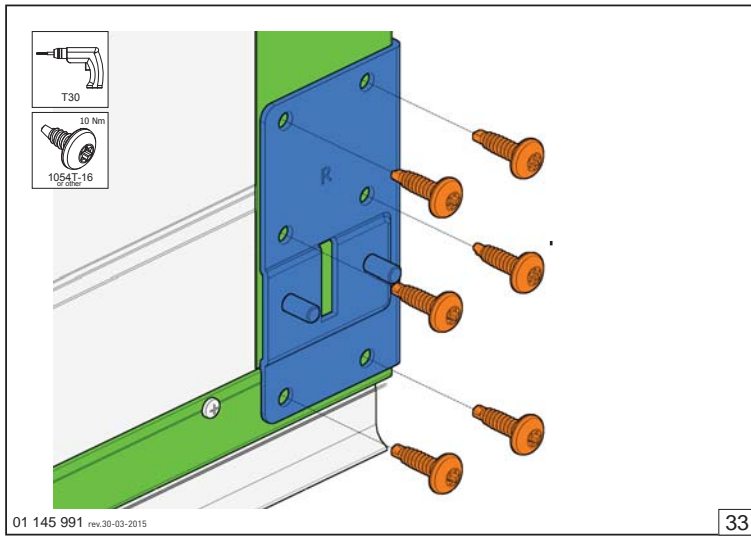

33

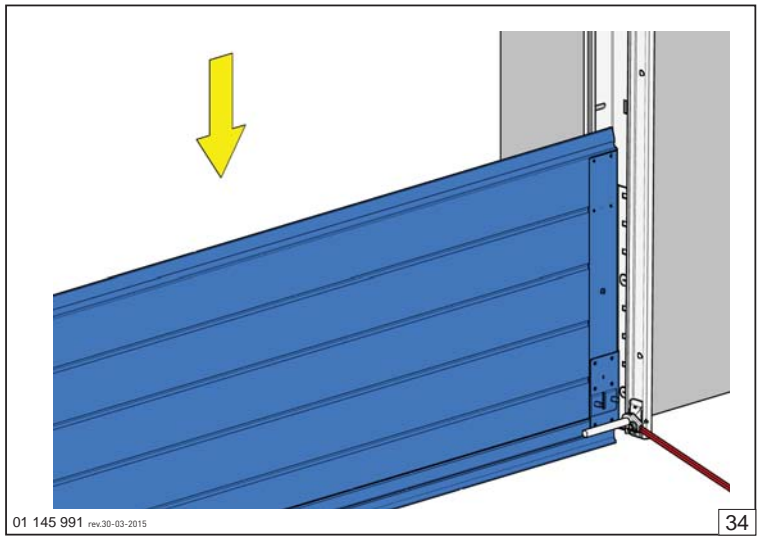

34

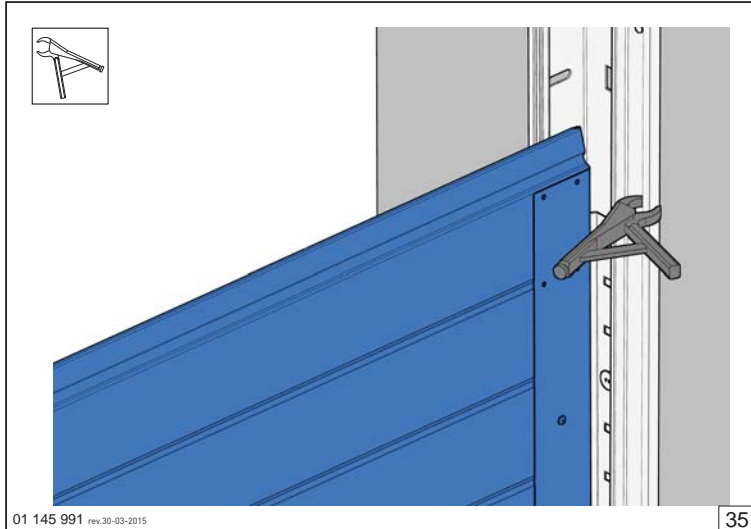

35

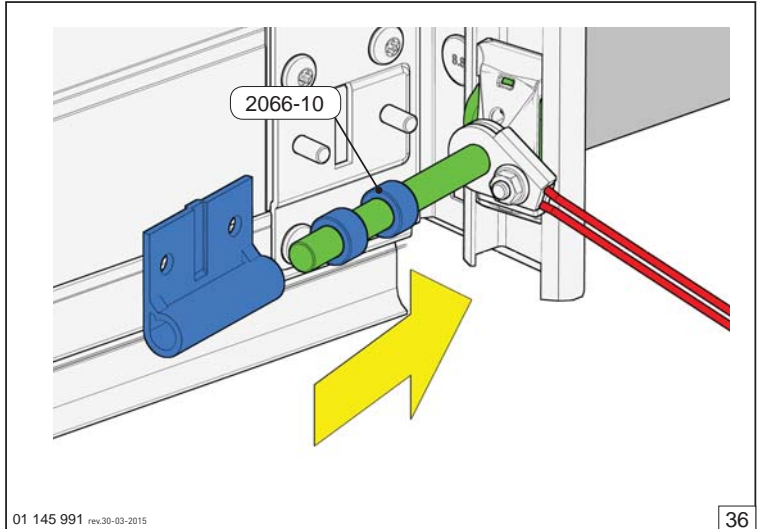

36

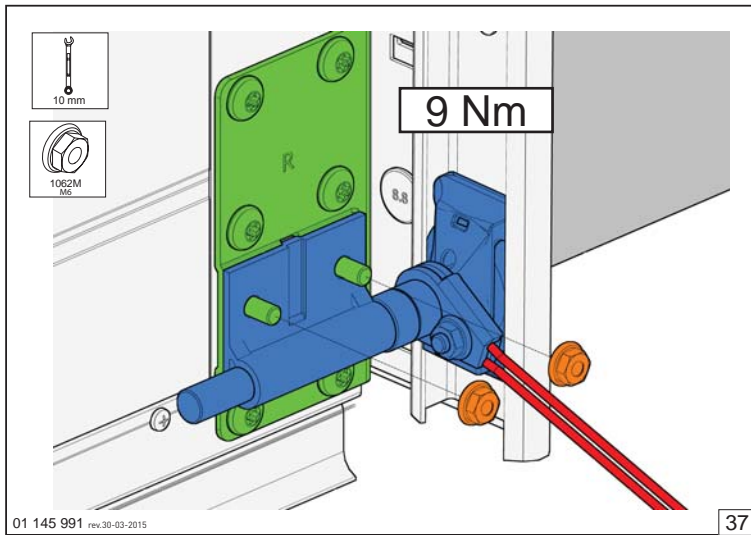

37

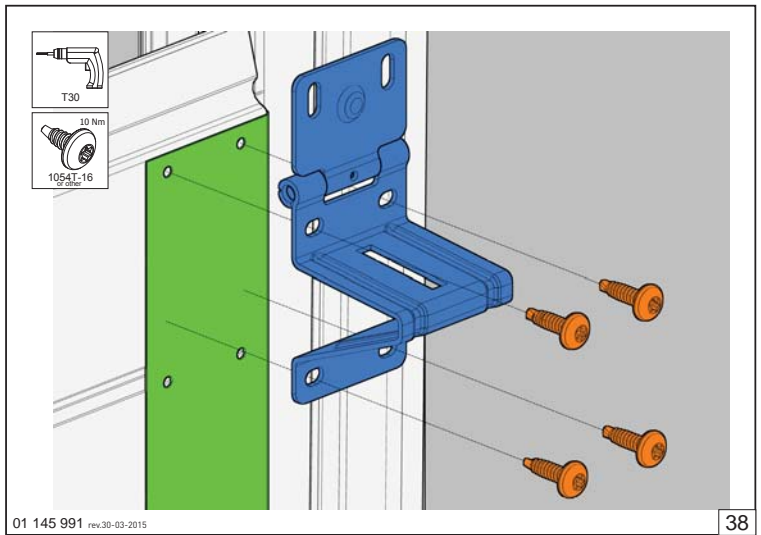

38

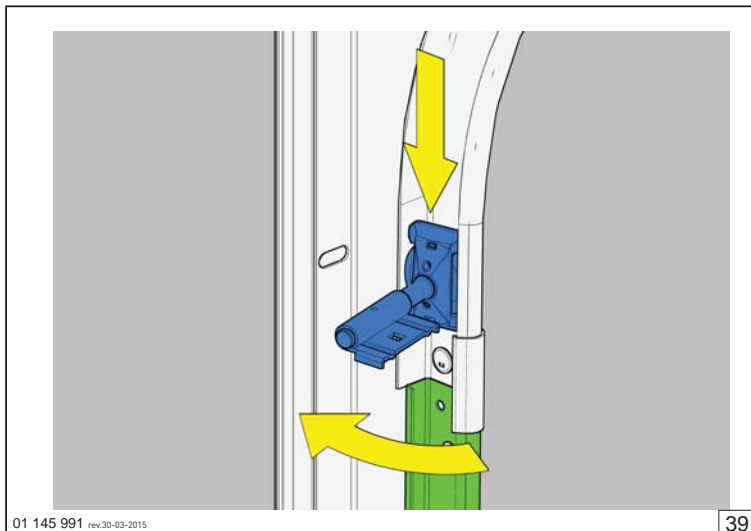

39

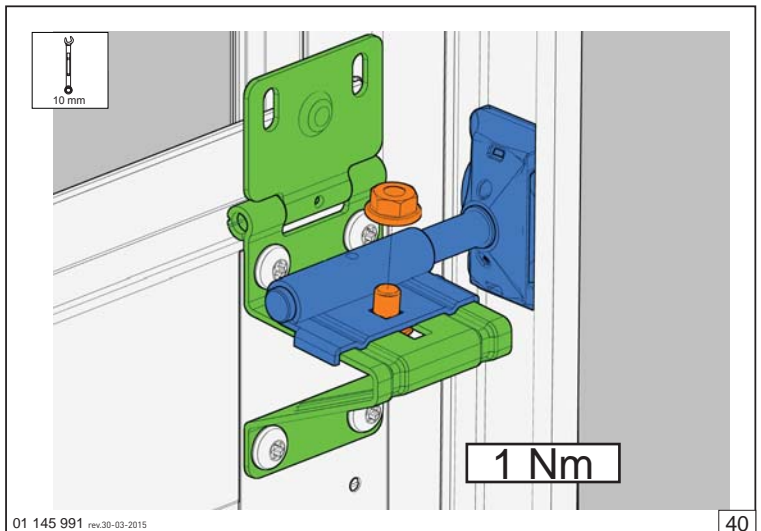

40

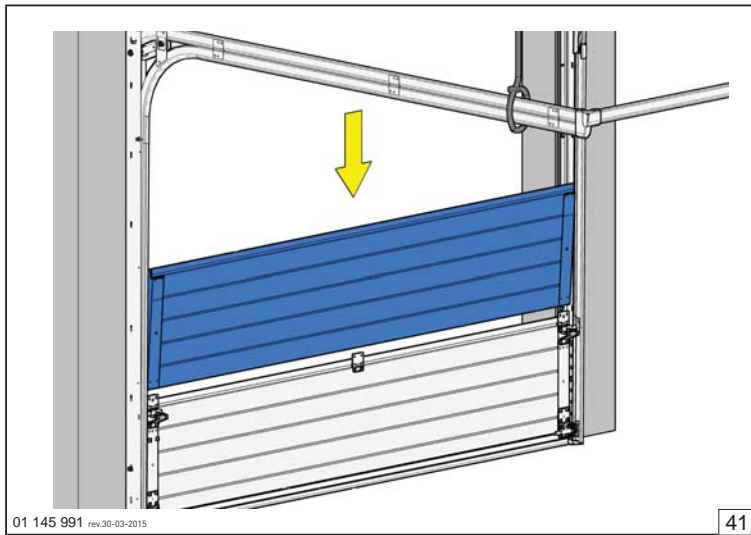

01 145 991 rev.30-03-2015

41

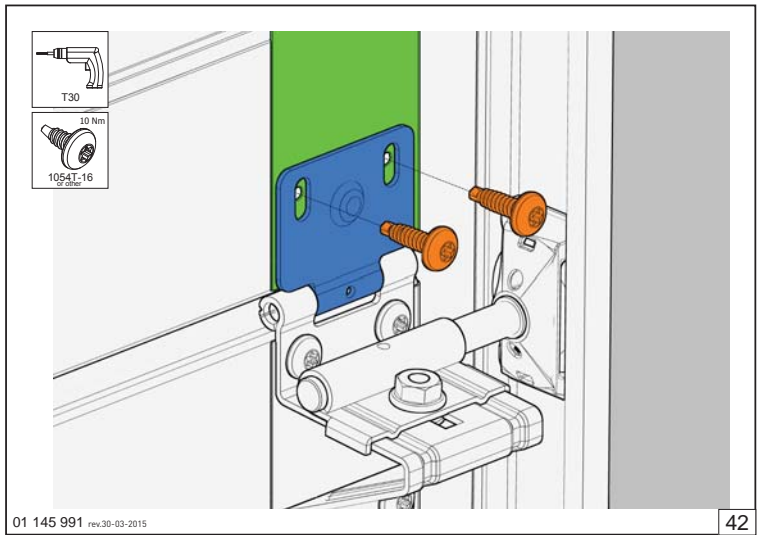

01 145 991 rev.30-03-2015

42

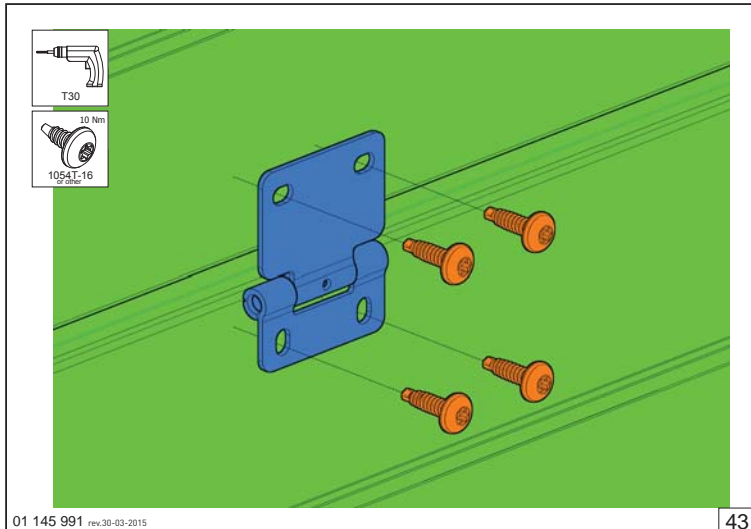

01 145 991 rev.30-03-2015

43

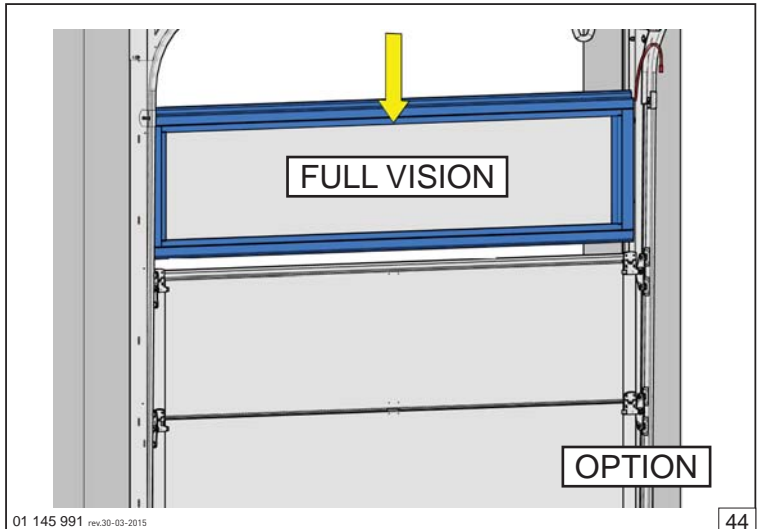

01 145 991 rev.30-03-2015

44

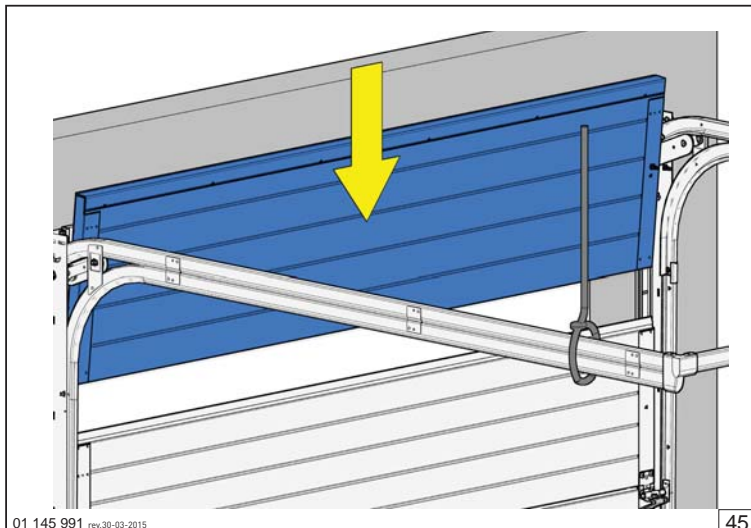

01 145 991 rev.30-03-2015

45

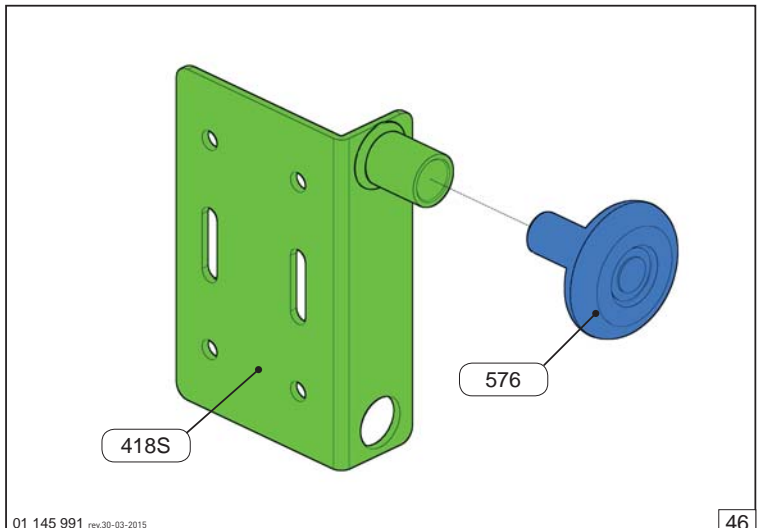

01 145 991 rev.30-03-2015

46

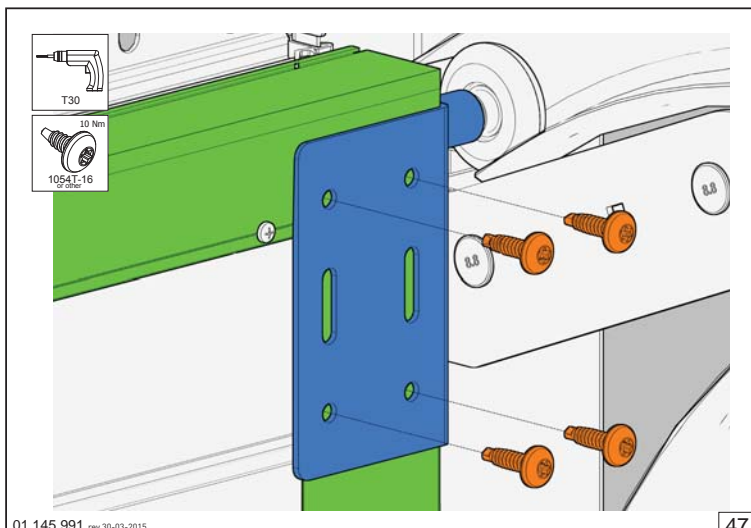

01 145 991 rev.30-03-2015

47

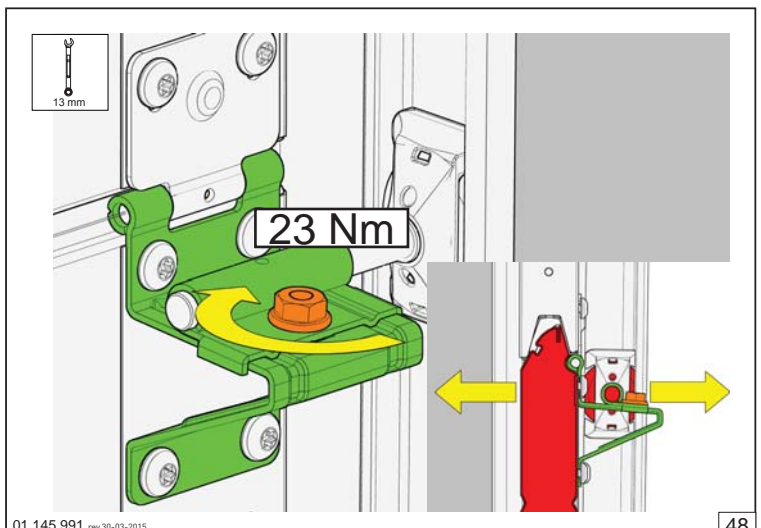

01 145 991 rev.30-03-2015

48

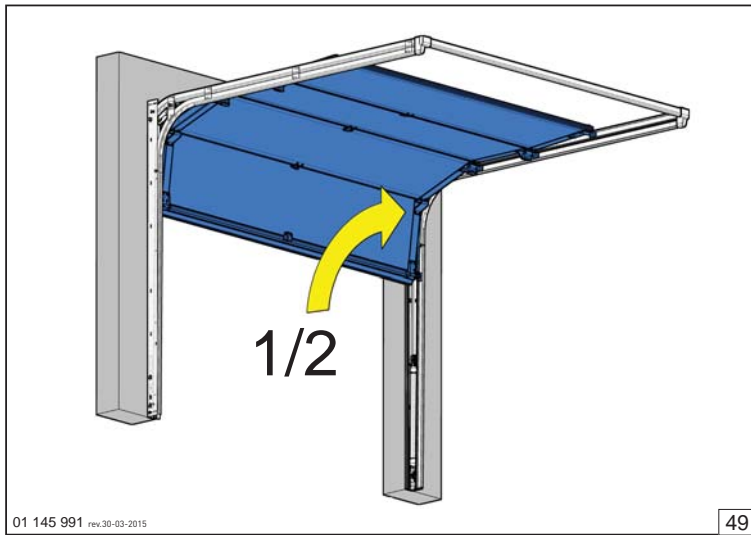

01 145 991 rev.30-03-2015

49

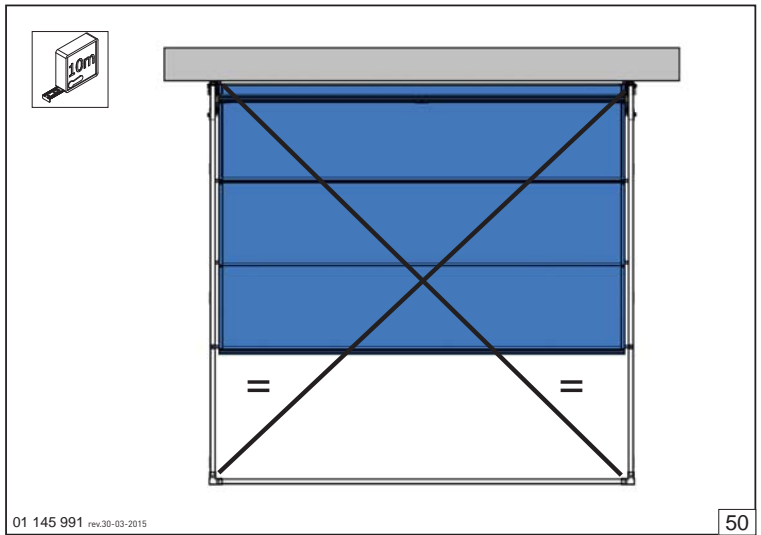

01 145 991 rev.30-03-2015

50

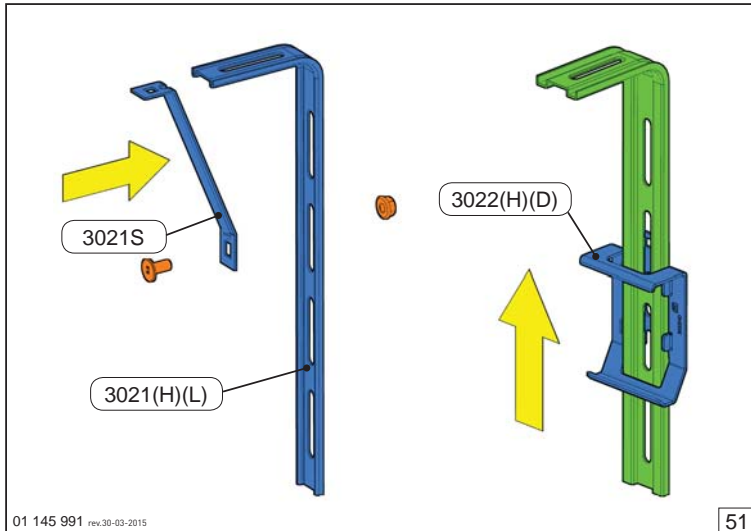

01 145 991 rev.30-03-2015

51

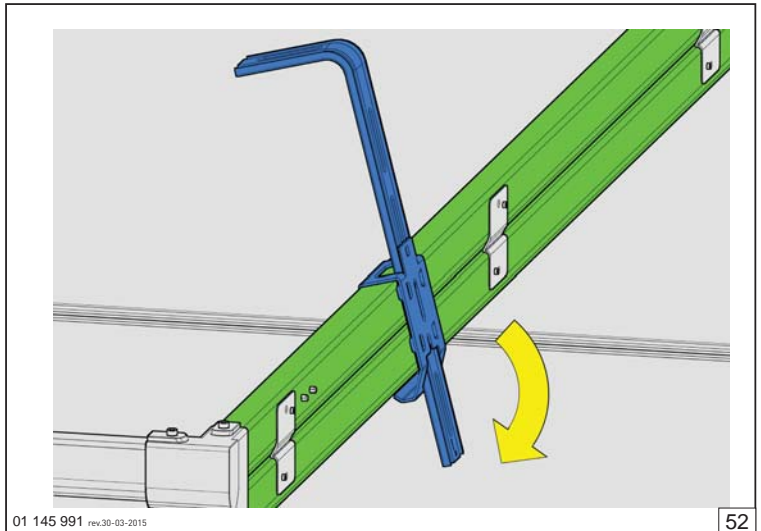

01 145 991 rev.30-03-2015

52

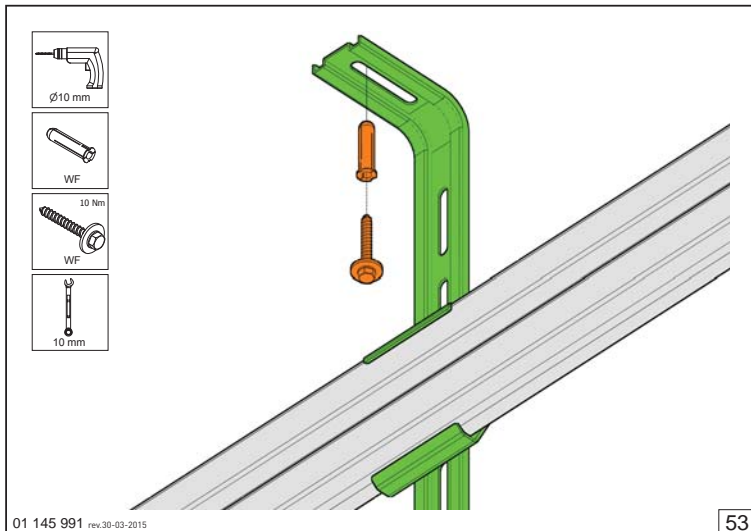

01 145 991 rev.30-03-2015

53

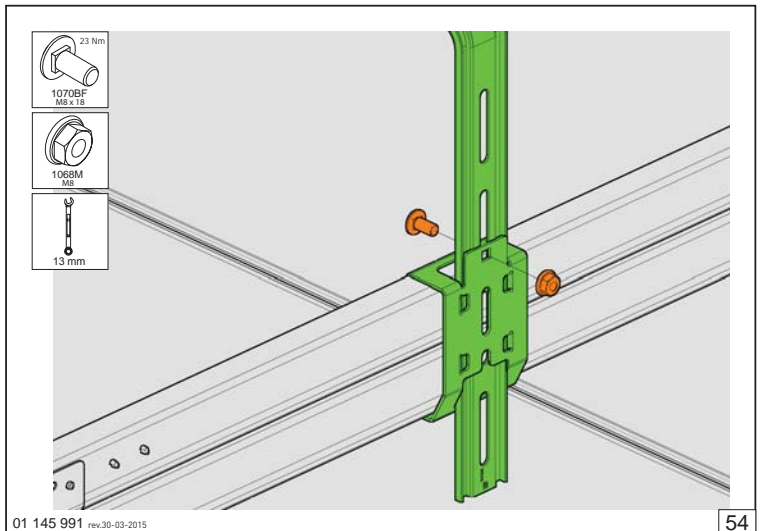

01 145 991 rev.30-03-2015

54

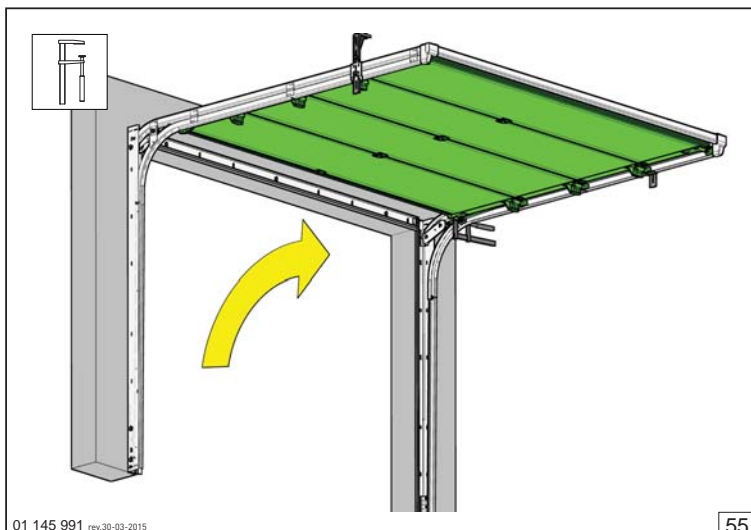

01 145 991 rev.30-03-2015

55

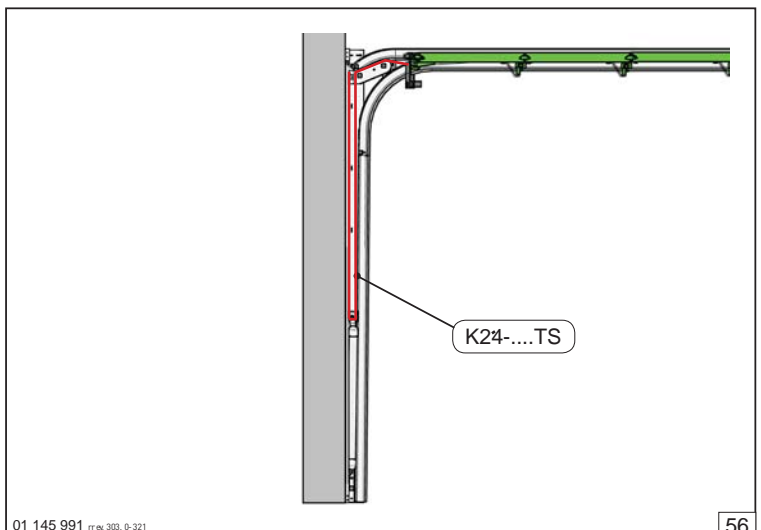

01 145 991 rev.30-03-2015

56

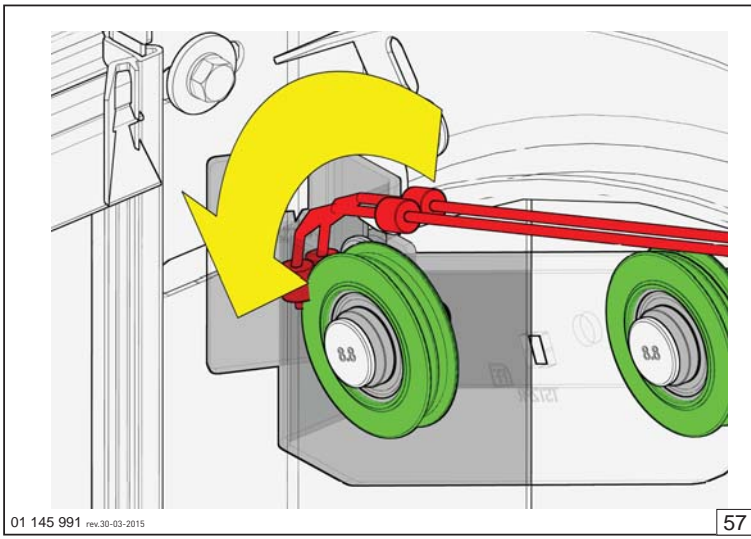

01 145 991 rev.30-03-2015

57

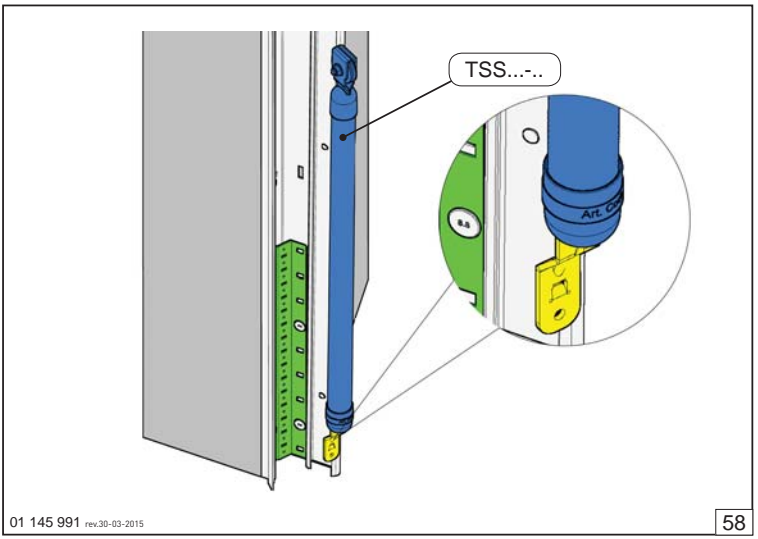

01 145 991 rev.30-03-2015

58

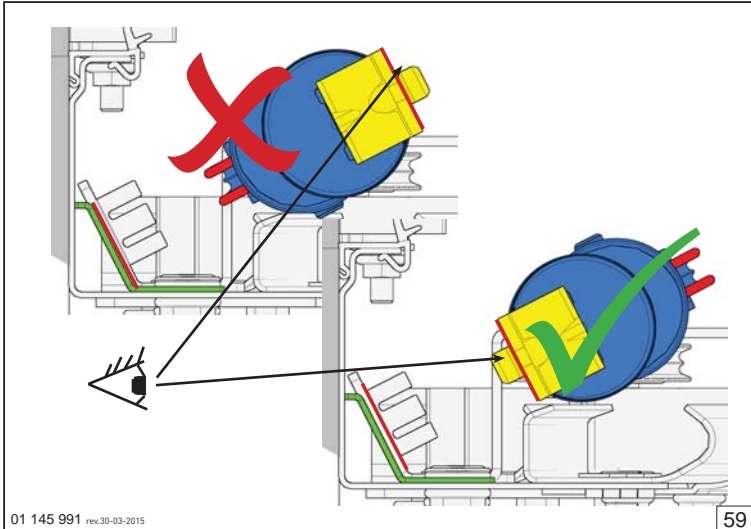

01 145 991 rev.30-03-2015

59

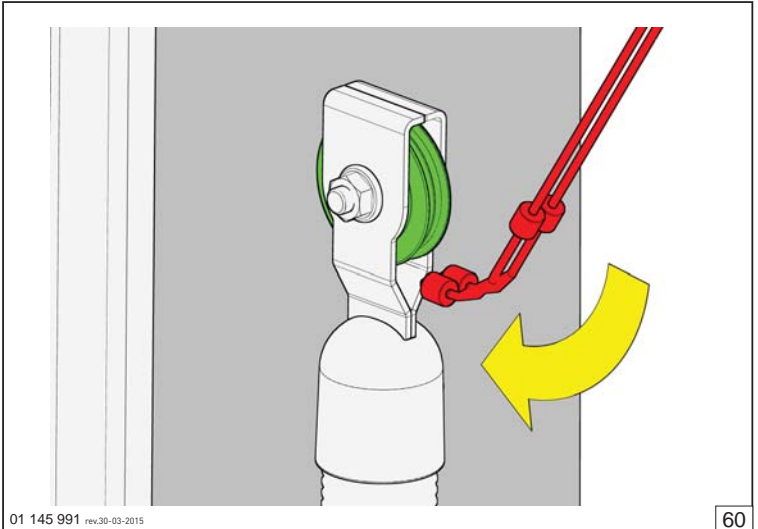

01 145 991 rev.30-03-2015

60

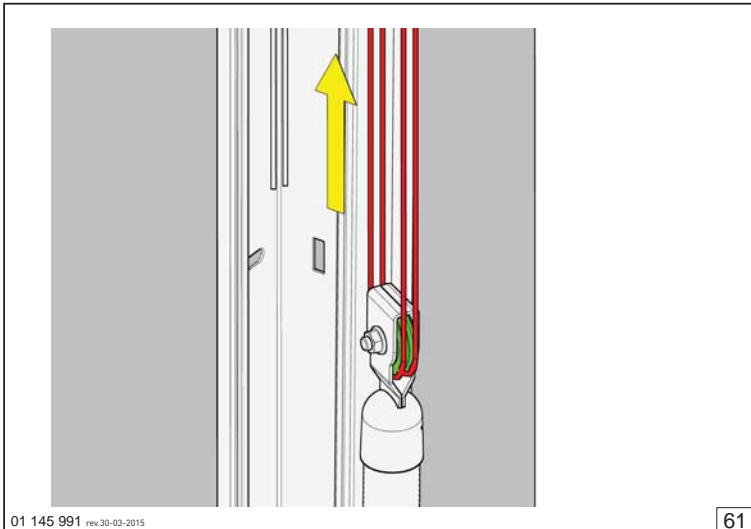

01 145 991 rev.30-03-2015

61

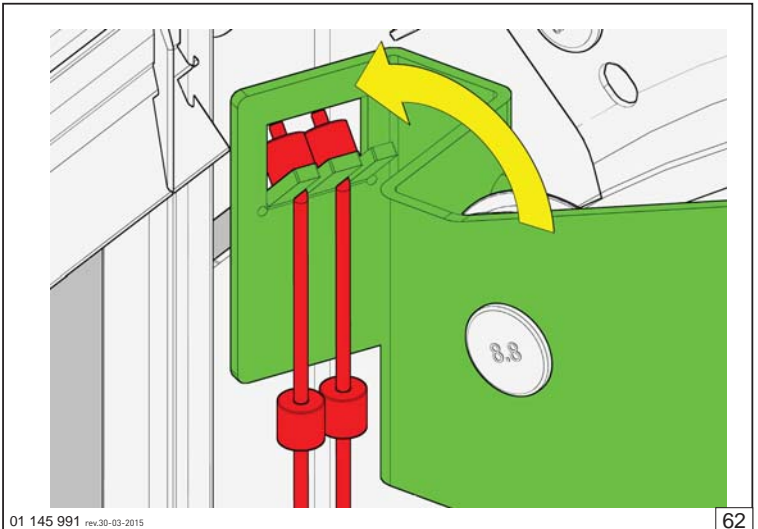

01 145 991 rev.30-03-2015

62



01 145 991 rev.30-03-2015

63

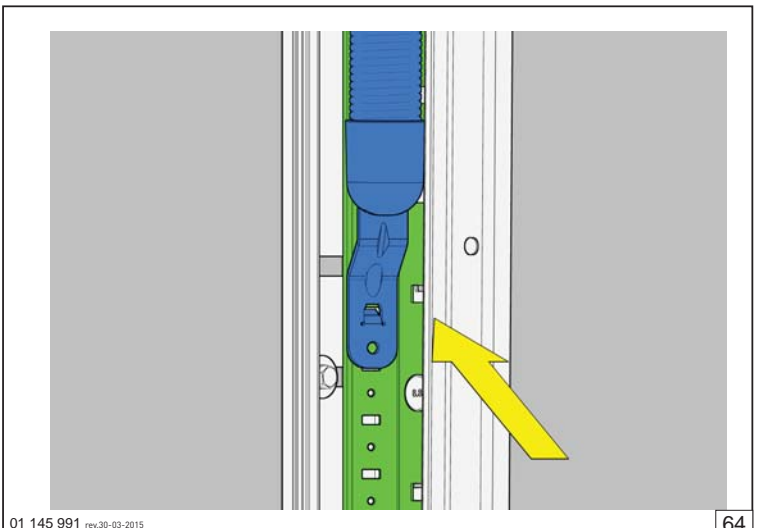

01 145 991 rev.30-03-2015

64

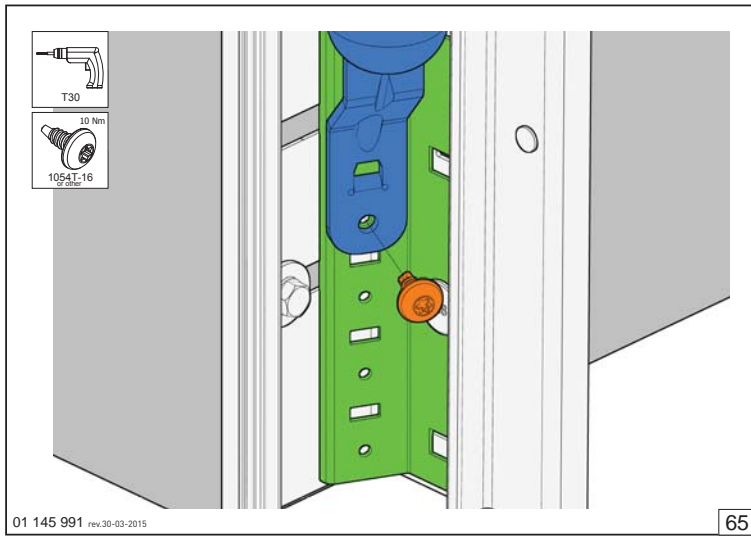

65

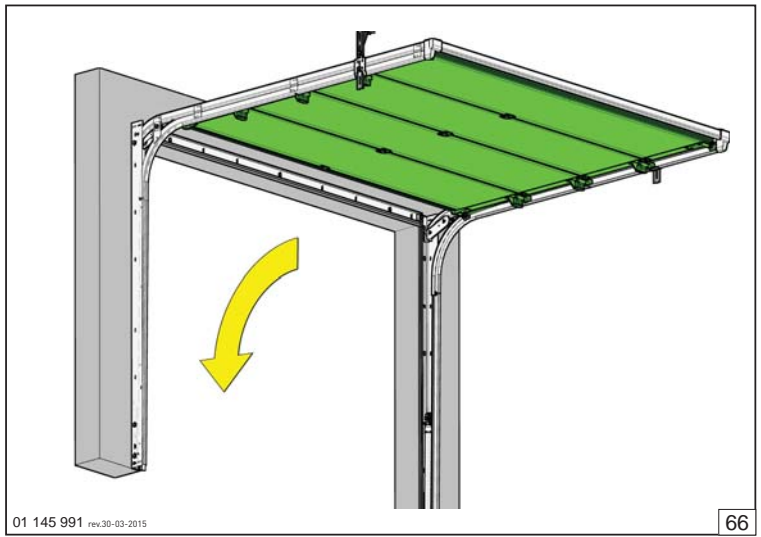

66

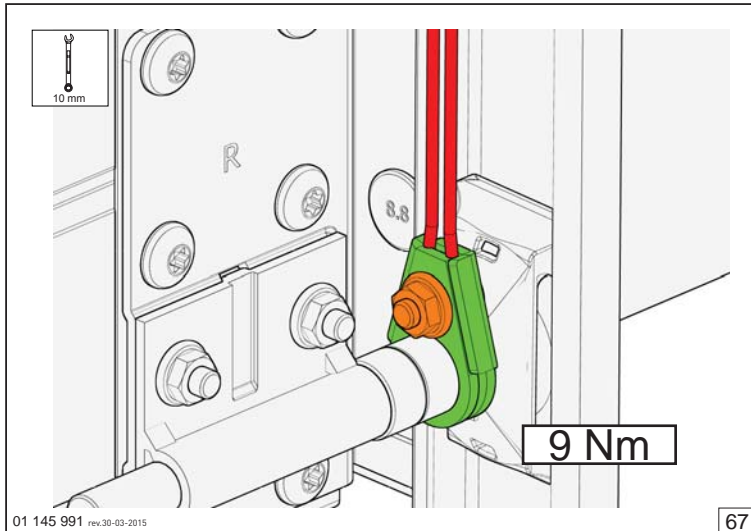

67

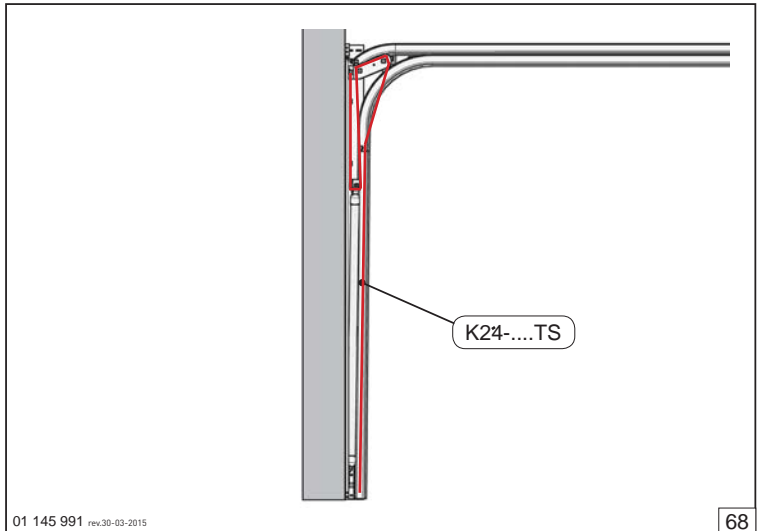

68

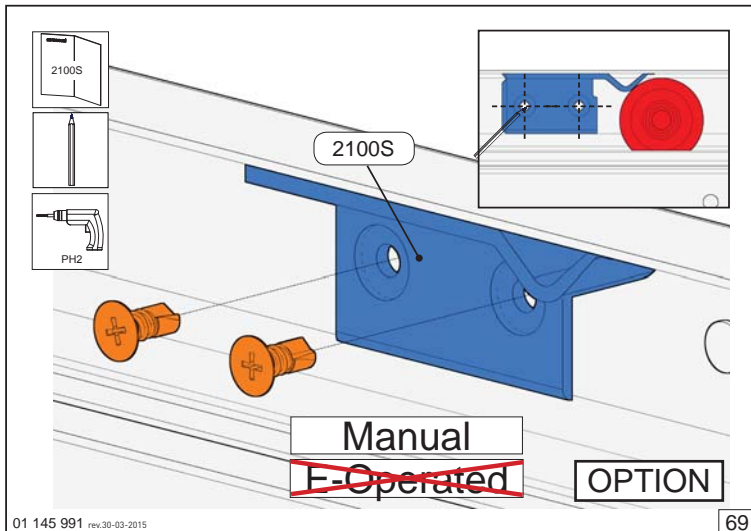

69

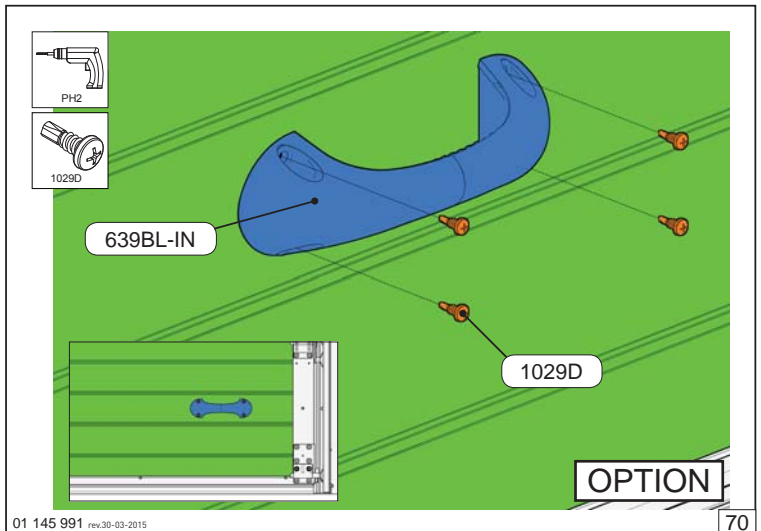

70

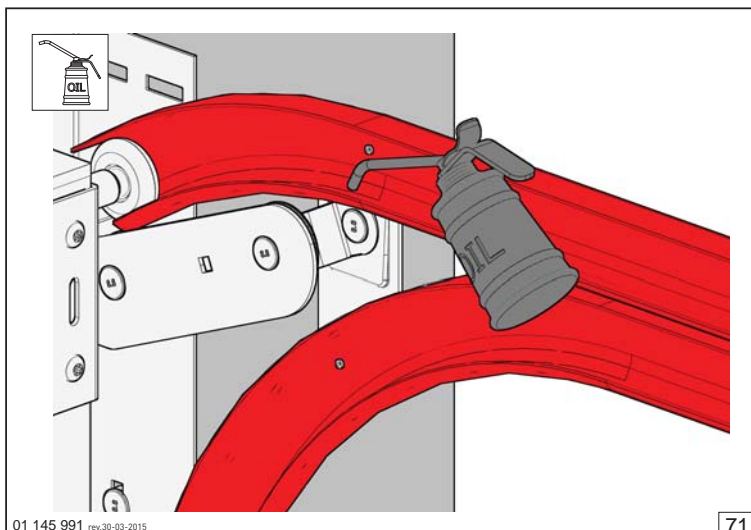

71

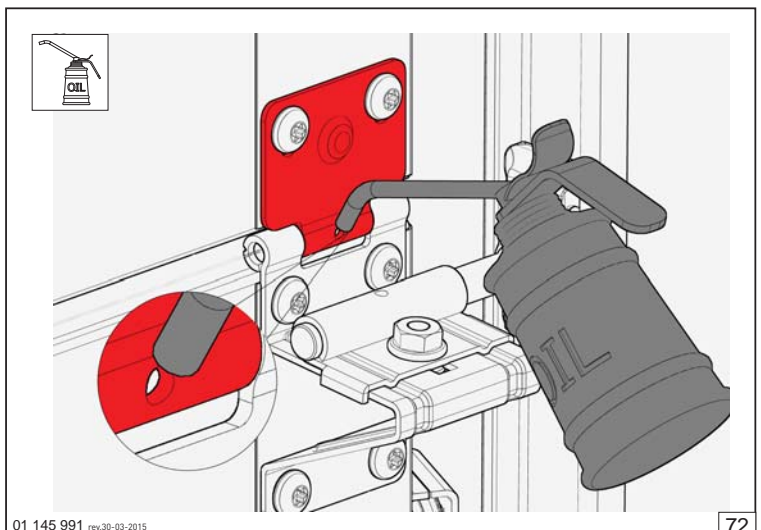

72

